

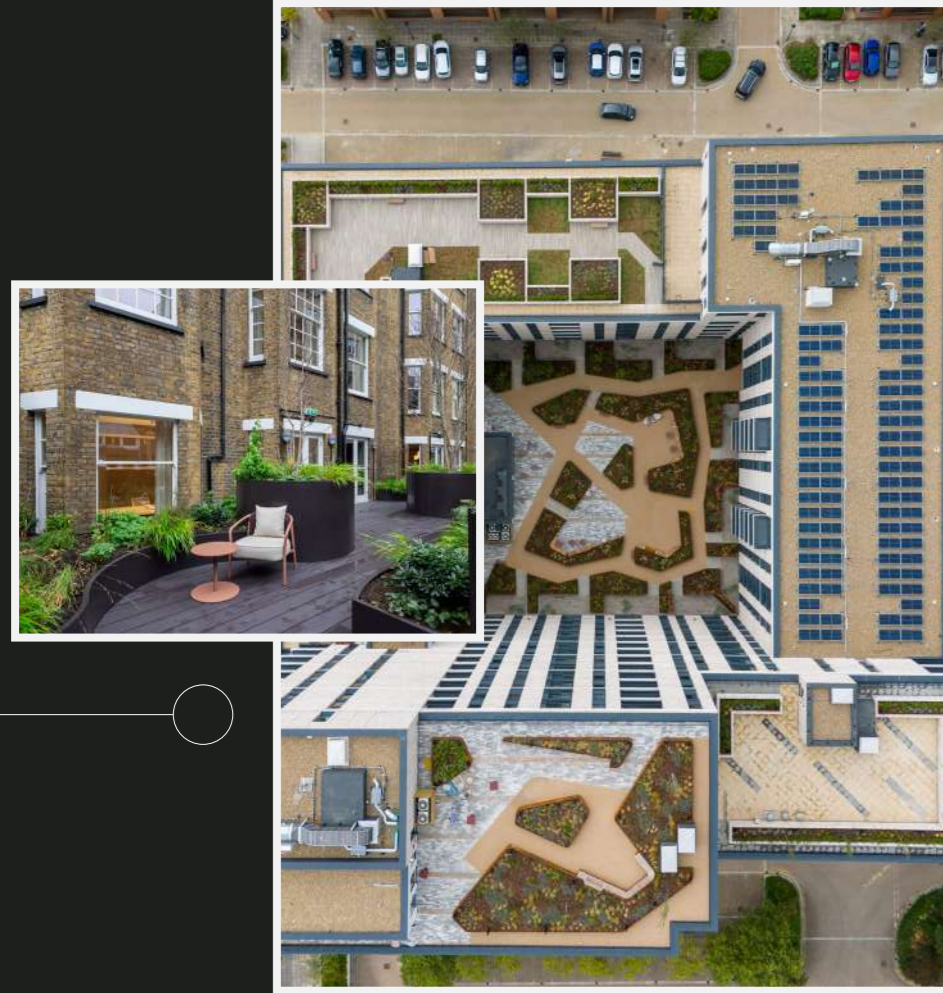

# THE ART OF ROOF TERRACES

Enhancing life on the skyline.  
This is our comprehensive guide  
to integrated roof terraces.





# COMPLETE INTEGRATED ROOF TERRACE SYSTEMS

HERE TO MAKE ROOF TERRACE PROJECTS EASIER. WE'VE BEEN AT IT FOR OVER A DECADE!

We get it, getting the detail of roof terraces right can be tricky. We're here to make life easier. With a complete suite of integrated roof terrace systems that combine paving, decking, surfacing, planters and balustrades.

We bring smart design and proper support together. We stick with you from early design to project completion, with solid technical advice and on-site know-how every step of the way.

LET'S TALK

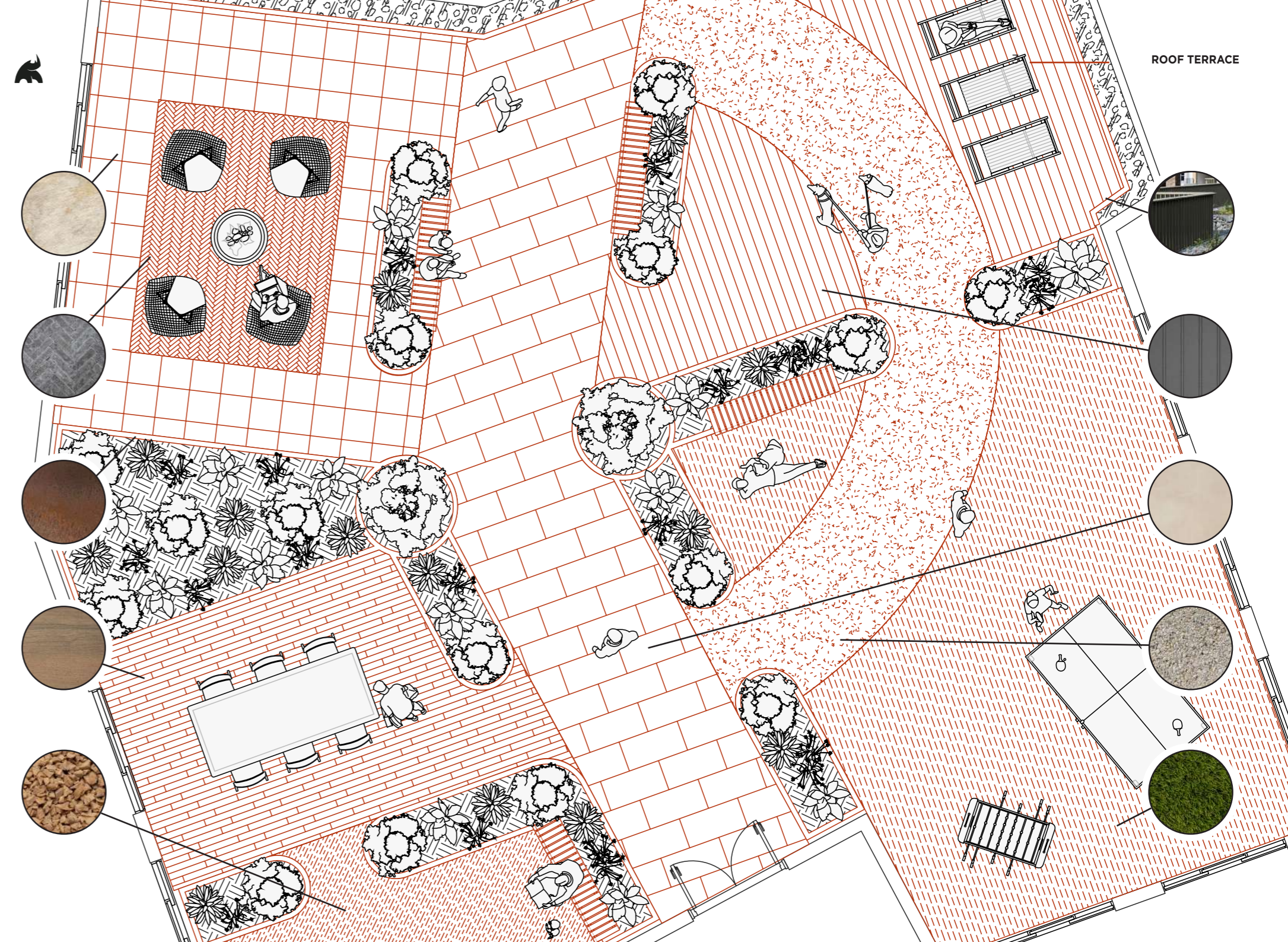



# ROOF TERRACE DESIGN METHOD

**A CLEAR, PURPOSE-DRIVEN METHODOLOGY TO HELP YOU DESIGN ROOF TERRACES THAT WORK.**

This five-step process helps architects and designers create roof terraces that are complete, coordinated, and fully integrated. Supporting every stage from defining the purpose to resolving structural and aesthetic details. Nothing is left disconnected or improvised. The goal is simple: to deliver your design intent without the headache of intensive coordination, and to create terraces that truly enhance life on the skyline.



1

## ARTICULATE THE PURPOSE

First, define the true purpose and function of the space. Go beyond the obvious - how will it actually be used, by whom, and when? A clear purpose sets the foundation for every design decision that follows.

P. 6

2

## VISUALISE THE SPATIAL PLAN

Let your creativity loose. Create however you create. Explore layout ideas, spatial flow, and visual impact. This is where your concept begins to take shape - expressive, ambitious, and aligned with the purpose.

P. 10

3

## ESTABLISH THE CRITICAL REQUIREMENTS

Driven by the intended use, these requirements can be broad, from access and maintenance needs to wind uplift and surface water mitigation. Establishing these early avoids surprises and keeps your design on track.

P. 14

4

## CURATE THE SURFACE LANGUAGE

Curate materials and finishes that support your vision, meet performance needs, and contribute to a cohesive, buildable scheme. Every surface, horizontal and vertical, should serve both form and function.

P. 22

5

## BUILD-UP THE SUPPORT SYSTEM

Thinking holistically matters. It's not just the build-up, but how each system and material works together to form a complete, integrated solution. Get this right early and avoid coordination headaches later.

P. 60



## STEP 1

# ARTICULATE THE PURPOSE

First, define the true purpose and function of the space. Go beyond the obvious - how will it actually be used, by whom, and when? A clear purpose sets the foundation for every design decision that follows.



# GET CLEAR ON THE PURPOSE EARLY

## COMMERCIAL AMENITY

Terraces that support workplace wellbeing; offering breakout zones, client-facing areas, and flexible outdoor environments for business use.

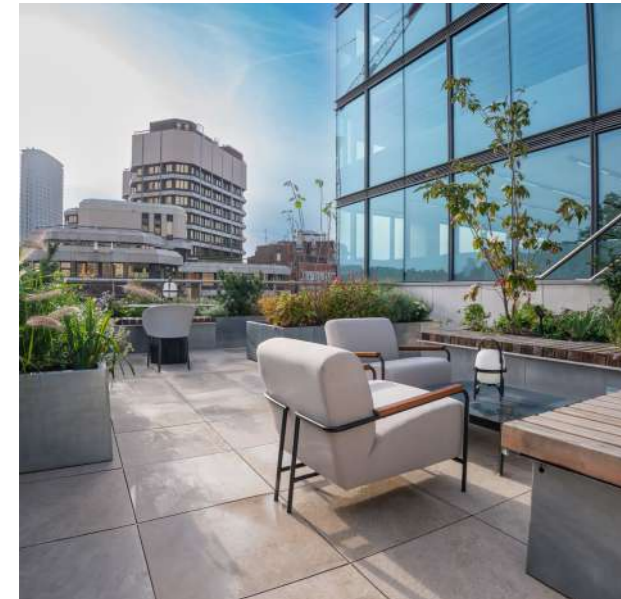

## PUBLIC REALM

Roof terraces designed for shared urban experiences - enabling social interaction, events, and community engagement in elevated settings.



## PUBLIC SECTOR AMENITY

Roof terraces supporting public institutions, from hospitals to schools. Terraces offer functional restorative and community-focused outdoor environments.



## RESIDENTIAL AMENITY

Private or shared terraces that enhance everyday living; with leisure, greenery, and comfort built into the residential experience.



## HOSPITABLY VENUE

Terraces that elevate dining and social settings, creating welcoming outdoor spaces for guests to relax, gather and enjoy their surroundings.



DEFINE THE TRUE PURPOSE OF YOUR SPACE

# LOOK BEYOND THE OBVIOUS

### Who's it for?

Is it for people passing through, or those who stay a while? Families, workers, older residents, students? Thinking about who might use the space helps you picture what would make it feel welcoming, without overthinking it.

### Why are they there?

Are they looking to switch off, catch up, take a breath, or just be somewhere different for a moment? It's worth considering what people need from the space emotionally, not just physically, before jumping into design decisions.

### What time is it?

Is it early morning, lunchtime, or later in the day? The time of use can change everything; how light moves, how warm it feels, how people behave and lighting that is required. It's a simple question that opens up a lot.

### How often, how many?

Is it a steady trickle or a busy rush? A few regulars or a crowd now and then? Getting a feel for the rhythm helps you shape something that holds up, feels balanced, and doesn't try too hard.





## STEP 2

# VISUALISE THE SPATIAL PLAN

Let your creativity loose. Create however you create. Explore layout ideas, spatial flow, and visual impact. This is where your concept begins to take shape - expressive, ambitious, and aligned with the purpose.



# LET THE SPACE TAKE SHAPE

## HOW DOES A ROOF TERRACE DESIGN ACTUALLY BEGIN?

We asked a couple of landscape architects to share their thoughts on the questions shaping today's outdoor spaces. Sam Bailey, Chartered Landscape Architect and consultant at SB-LA and Mia Tian, Assistant Landscape Architect at Camlins, gave us their take.

### Here's what they said:



What's the first thing you put down on paper and why?

The outline of the space. Size, scale and form. What the adjacent built form is doing, where the views are. Then bubble out function - what the space will be used for. Where does the sun go. Where's the windiest spots.

Do you sketch in layers - structure first, then planting, then detail?

Get the spatial arrangement right first. The spaces need to feel right on the plan, at the right scale and balanced in the overall design. They shape / form of them can vary but need to be a consistent design language. You know you have it when the plan sits quietly on the page.

Once the spaces are set then you can add variety and fun with the planting and the detail - materials, junctions, interesting things.



Do you sketch with a mood in mind, or let it emerge as you go?

You need to be relaxed and let ideas emerge naturally. It can't be forced and usually involves loose pencil sketches whilst listening to music.

What does a "good sketch" look like to you - expressive, clear, or intentionally loose?

As early stages, I think a good sketch can be expressive and engaging, while still communicating ideas in a loose and flexible way. From my experience on Stage 2 projects, sketches are effective in conveying overall spatial intent without committing too early to detailed design or precise scale. This ties with my design approach, where I prefer to establish a clear overarching strategy before moving into finer detail. I see sketches as a valuable way to both inspire ourselves and communicate with the client, while leaving room for the design to



evolve through further discussion. That said, I believe any output at this stage should still be clear enough to be easily understood and communicated.



Do you ever sketch from the inside out - imagining how it feels to be there?

Yes, I believe landscape design is not only about 2D plan drawings, but more importantly about user experience, buildability, and how the design responds to relevant regulations and constraints.

At any early stage, perspective drawings can be particularly effective in communicating the experience, helping to convey spatial quality.

Do you tend to start with pen and paper, or go straight to screen?

Most of us in the practice tend to start with a pen and paper approach. Depending on the scale of the project, we may return to sketching at various stages to resolve specific areas within.



### STEP 3

# ESTABLISH THE CRITICAL REQUIREMENTS

Driven by the intended use, these requirements can be broad, from access and maintenance needs to wind uplift and surface water mitigation. Establishing these early avoids surprises and keeps your design on track.



# WHERE DESIGN MEETS REALITY

Fire Compliance	16
Wind Uplift Mitigation	17
Slip Resistance, Surface Water and Ice	18
Access For All	18
Maintenance Considerations	19
Loadings Requirements	19
Substrate Compatibility	20
Biodiversity Net Gain	20
Budget Considerations	21



## FIRE COMPLIANCE

The regulatory landscape for fire safety in external building elements has evolved significantly since the Grenfell Tower fire. In the UK, fire performance is assessed using different classification routes depending on whether an element is considered a material, system, external wall component, or roof covering. BS EN 13501-1 remains the standard for classifying the reaction to fire of construction products (Euroclasses A1-F), while BS EN 13501-5 applies specifically to the fire performance of roof coverings.

BS EN 13501-5 classifies roof coverings based on testing to CEN/TS 1187, which simulates external fire exposure through thermal attack, burning brands, wind, and radiant heat. A B<sub>ROOF</sub>(t4) classification demonstrates the highest level of roof performance, including no fire penetration, limited flame spread, and controlled burn duration. In addition, certain roof coverings are recognised under European Commission Decisions made under the Construction Products Regulation as providing adequate resistance to external fire exposure without the need for testing, provided the construction and materials strictly meet the defined criteria.

For communal roof terraces, particularly those used for amenity or circulation, the surface build-up and finishes may be assessed as the roof covering where they form the exposed weathering



layer of the roof. In such cases, external fire performance is appropriately addressed in accordance with BS EN 13501-5, using classifications derived from CEN/TS 1187 testing or applicable European Commission Decisions. Height thresholds such as 11 metres relate to external wall provisions within the Building Regulations and do not, in themselves, determine whether a roof terrace or its finishes should be assessed under BS EN 13501-5; this should instead be established through Approved Document B, BS 9991, and the project fire strategy.

Ryno's terrace solutions are designed to support compliance with these requirements; however, the correct classification route depends on how the terrace is defined within the fire strategy. Early coordination with the project fire engineer remains essential to ensure full compliance with UK Building Regulations and site-specific fire risk conditions.

**Roof covering products and/or materials which can be considered to fulfill all of the requirements for the performance characteristic 'external fire performance' without the need for testing, subject to any national provisions on the design and execution of works being fulfilled.**

**Tiles:** stone, concrete, clay, ceramic or steel roof tiles

**Profiled metal sheets:** aluminium

Loose laid gravel with a thickness of at least 50 mm or a mass  $\geq 80 \text{ kg/m}^2$  (minimum aggregate size 4mm, maximum 32mm)

Sand/cement screed to a thickness of at least 30 mm

Cast stone or mineral slabs of at least 40 mm thickness



## WIND UPLIFT MITIGATION

Effective wind mitigation begins with understanding the forces at play. This assessment should start as early as the planning stage, enabling designers to make informed decisions that influence the terrace's build-up, support structure, and material selection. Wind uplift poses serious risks to the integrity and safety of roof terrace systems, particularly in exposed or elevated locations.

Mitigation strategies vary depending on the chosen floor finish, format, and system type. Options include increasing the dead weight of the system, anchoring it to the structure, and/or mechanically connecting the components to form a unified, wind-resistant assembly.

Aesthetics must be carefully considered, especially for porcelain and natural stone paving. Some systems offer completely hidden solutions, while others rely on discreet but visible fixings to achieve compliance without compromising visual appeal.

By addressing wind uplift early and holistically, architects and specifiers can ensure the terrace system remains secure, compliant, and visually coherent throughout its lifecycle. To discuss wind mitigation options tailored to your project, get in touch with our technical team, we're here to help - [specification@rynosystems.com](mailto:specification@rynosystems.com).



## SLIP RESISTANCE, SURFACE WATER AND ICE

Safety and slip resistance are critical considerations in surface design. All systems must achieve a minimum of 36 PTV in accordance with BS EN ISO 16165:2021, verified through certified test laboratories and detailed specification writing to ensure full compliance. Surfaces should maintain slip resistance in both wet and dry conditions, with increased resistance required for sloped or ramped areas due to elevated risk. It is important to note that slip resistance becomes ineffective when ice is present.

Standing water is a key contributor to ice formation and presents a hazard even in non-freezing conditions. This is particularly relevant for porcelain paving, where surface tension can cause water to remain on the top surface. To address this, a tried and tested specialist drainage spacer is used to break the surface tension and allow water to drain freely. This not only reduces the risk of ice buildup but also improves overall safety and usability in wet conditions.



## ACCESS FOR ALL

Designing for inclusive access is a key part of creating usable outdoor spaces. Where ramps are required, it's important to use a double rail system to safely manage lateral loads as people move across the surface. Handrails should be thoughtfully integrated to support accessibility and enhance user confidence.

Achieving a level threshold can be particularly challenging on projects with low height build-ups, often resulting in cantilevered finishes that require careful detailing. To ensure safe and compliant spacing between pavers or decking, BS 8579:2020 recommends a maximum gap of 8mm, helping to prevent trip hazards and support smooth transitions for wheelchair users and those with mobility aids.



## MAINTENANCE CONSIDERATIONS

Maintenance planning goes beyond keeping surfaces clean and visually appealing. It should also account for practical access to key infrastructure, such as davit arm sockets, rainwater outlets, and planting zones. These elements are often integrated into roof terraces and podium landscapes, and their accessibility is essential for long-term functionality and safety.

Designs should allow for straightforward inspection and servicing without compromising the aesthetic or structural integrity of the space. Early coordination between design and maintenance teams helps ensure that these features are both discreet and accessible, supporting a space that performs well over time.

## LOADINGS REQUIREMENTS

Roof terraces must be designed to safely accommodate their intended use, as this directly governs the structural loading requirements. Areas intended for light residential activity may be designed for imposed loads in the range of 1.5–2.0 kN/m<sup>2</sup>, while terraces functioning as walkways or communal spaces typically require higher design loads of 5.0–7.5 kN/m<sup>2</sup>. In addition, concentrated loads of up to 4.5 kN maybe required depending on the use of the space.

These higher loadings are frequently overlooked, especially when terraces double as access routes or gathering spaces. It's also essential to consider how loads are transferred through pedestal systems, as excessive pressure can compromise insulation or waterproofing layers and potentially void warranties.

Early coordination between design and structural teams ensures the surface system and underlying build-up are both safe and fit for purpose.



## SUBSTRATE COMPATIBILITY

Closely tied to the loading requirements, substrate compatibility is a critical part of roof terrace design. It's not just about how much weight the surface can carry, but how that load is transferred to the roofing layers below - including insulation and waterproofing. Both dead loads (the weight of the terrace system itself) and live loads (foot traffic, planters, maintenance equipment) must be considered.

Heavy items such as planters can introduce significant point loads, and maintenance activities - such as load testing of davit arm sockets - are often overlooked but critical. To protect the waterproofing during and after installation, appropriate base shock pads and spreader plates should be specified to absorb impact, distribute loads, and prevent damage to the roof build-up.

By coordinating substrate compatibility alongside load planning, designers can ensure long-term performance and avoid compromising warranties or structural integrity.



## BIODIVERSITY NET GAIN

Biodiversity Net Gain (BNG) encourages designers to enhance the ecological value of their projects, ensuring that development leaves nature in a better state than before. Roof terraces offer a unique opportunity to contribute to this goal, especially in urban areas where ground-level space is limited.

By integrating features such as planting zones, green roofs, and habitat elements, roof terraces can support pollinators, improve ecological resilience, and contribute to a healthier urban environment. These interventions also deliver wider benefits like urban cooling, improved air quality, and flood mitigation.

One practical way to meet BNG objectives is through the Urban Greening Factor (UGF) - a design-led approach that helps quantify and plan green infrastructure within the built environment. UGF provides a framework for incorporating meaningful greening into roof terraces, ensuring that biodiversity is considered from the outset and embedded into the design.

With thoughtful planning, roof terraces can become vibrant, multifunctional spaces that support both people and nature - helping meet policy goals while adding real value to the project.



## BUDGET CONSIDERATIONS

Budget is a critical driver in achieving the design intent of roof terraces. If financial constraints or opportunities are not understood from the outset, the project becomes vulnerable to significant design changes and value engineering (VE) that can compromise key features and lead to design failure. VE often overlooks complex design challenges when cost becomes the dominant focus.

To mitigate this risk, budget alignment should be one of the first steps in the design process. Early collaboration between stakeholders allows teams to identify cost efficiencies without sacrificing the integrity of the design. This is especially important for roof terraces, where structural, drainage, and access requirements must be resolved upfront. A well-considered approach balances ambition with practicality, ensuring that materials, systems, and detailing are achievable within budget - protecting the vision and avoiding costly redesigns or delays during construction.



CALVIN DALRYMPLE



HARVEY LOCK



ARRON THOMSON

**TALK TO SOMEONE WHO DEALS WITH THESE EVERY DAY**



No pressure, just helpful advice to guide your project in the right direction.

EMAIL  
hello@rynosystems.com

PHONE  
+44 203 967 3500



## STEP 4

# CURATE THE SURFACE LANGUAGE

Curate materials and finishes that support your vision, meet performance needs, and contribute to a cohesive, buildable scheme. Every surface, horizontal and vertical, should serve both form and function.

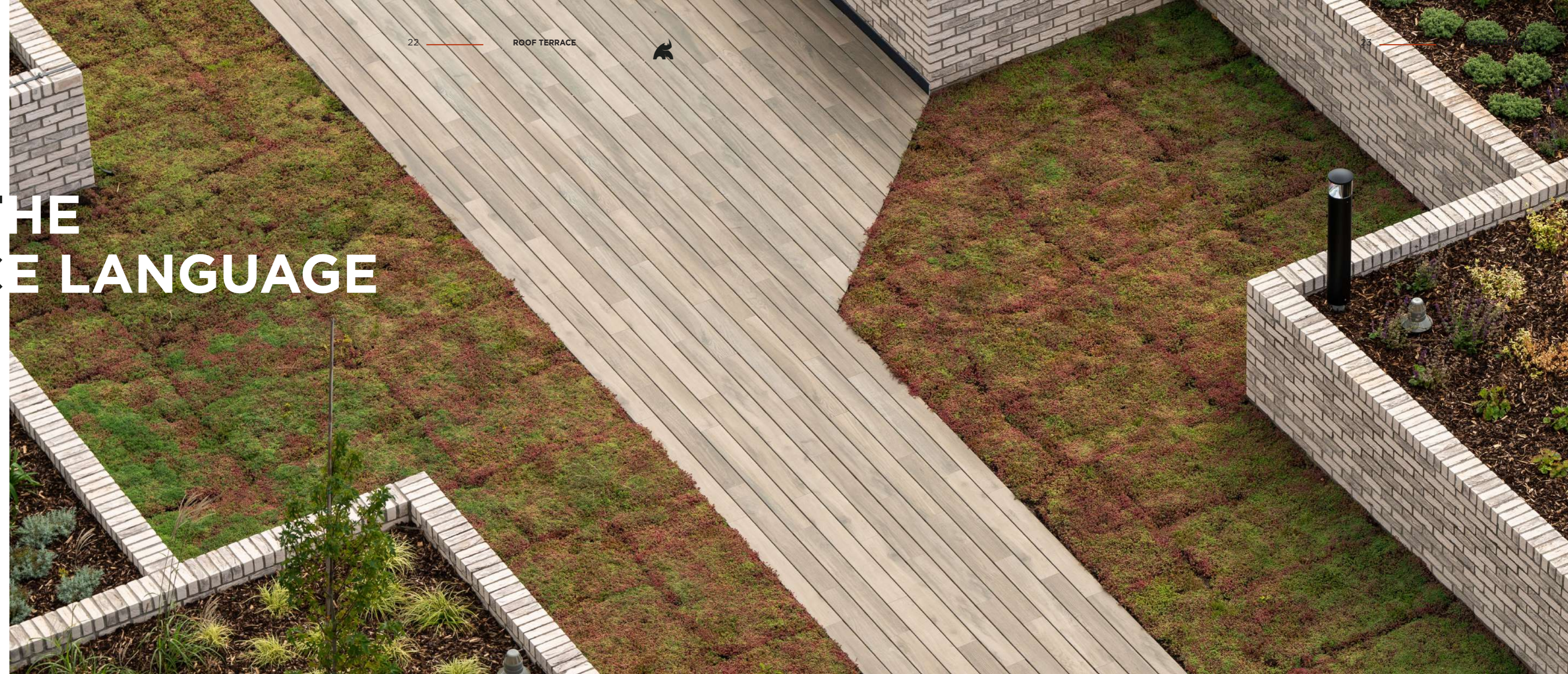



# CRAFT THE MATERIAL STORY

## COLOUR TONALITY

Colour is one of the most immediate ways to set the emotional tone of a terrace. Warm tones like creams, beiges, and corten steel, create a relaxed, earthy feel that suits social zones and softer planting schemes. Cool tones like greys, graphite, and raw metalwork, lend a sleek, architectural edge, often complementing minimal layouts and structured planting.

These tones are expressed through materials like stone, porcelain, powder-coated finishes, and sealed or imitation metallics. The choice of colour is about aesthetics combined with

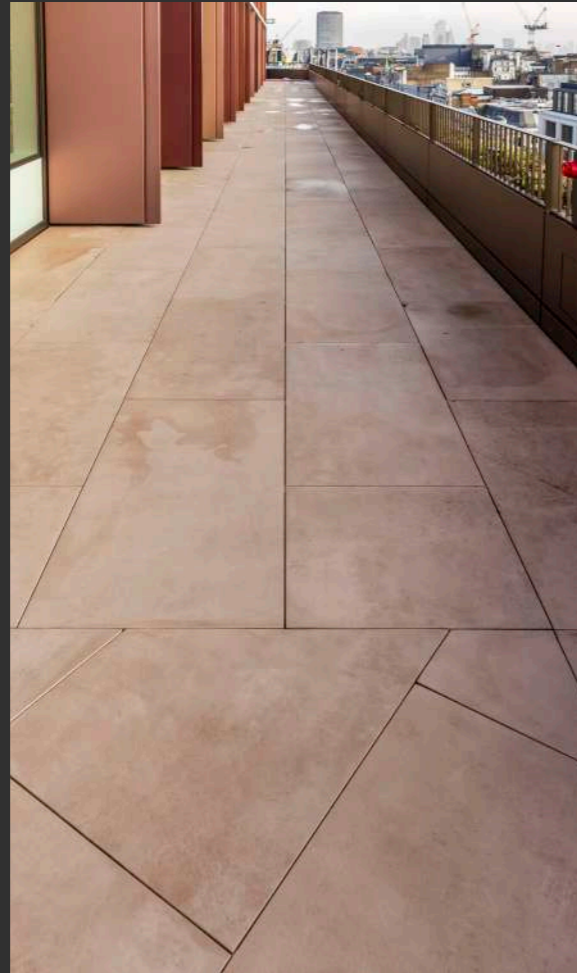

atmosphere. It influences how people feel in the space, how they move through it, and how it connects to its surroundings.

Designers should also consider how colour interacts with natural light. South-facing terraces may amplify warmth, while shaded areas benefit from lighter tones to lift the mood. Planting plays a role for; green foliage, flowering accents, and seasonal changes all affect how colour is perceived. Colour tonality is the first layer of emotional intent.



## TEXTURE EXPRESSION

Texture brings depth, character, and sensory richness to a terrace. It's not just about how materials look - it's about how they feel underfoot, to the touch, and how they respond to light and shadow throughout the day. Tactile surfaces like resin-bound gravel, decking planks, and imprinted pavers offer physical texture that invites interaction and adds visual interest.

Porcelain finishes can deliver visual texture through designs that mimic natural materials like stone and woodgrain, or present simple concrete and screed looks for a clean, contemporary aesthetic. Timber introduces warmth and softness, especially when used in seating or planter cladding, helping to balance hardscape elements with a more human, approachable feel.

Planting adds a further, crucial layer of texture, for example, grasses, layered foliage, and

seasonal blooms bring movement and softness that contrast beautifully with structured surfaces. Texture expression is about creating a dialogue between materials and mood. It helps define zones, soften edges, and elevate the sensory experience of the terrace, making it feel more immersive and emotionally engaging.

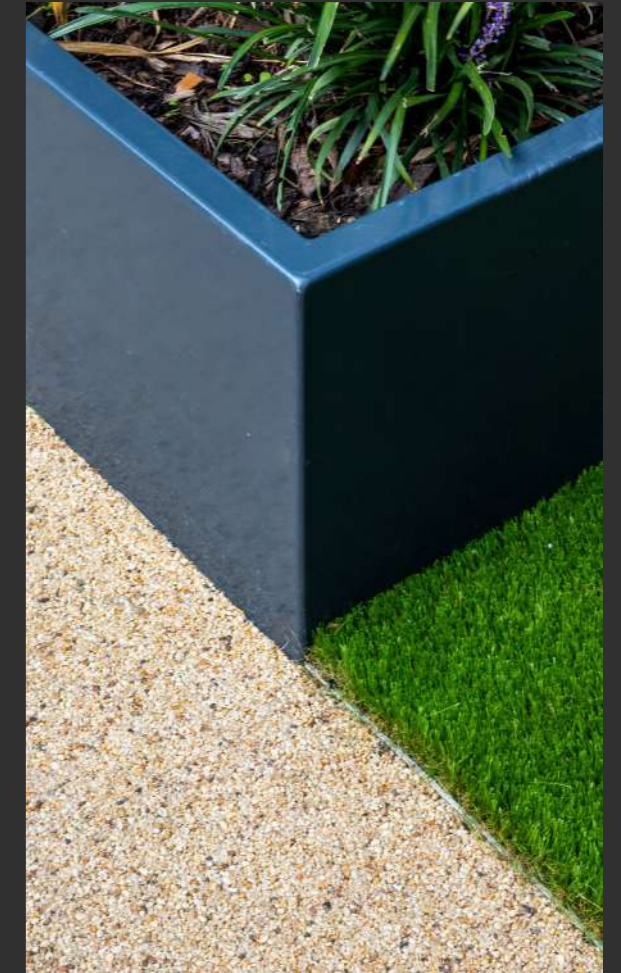
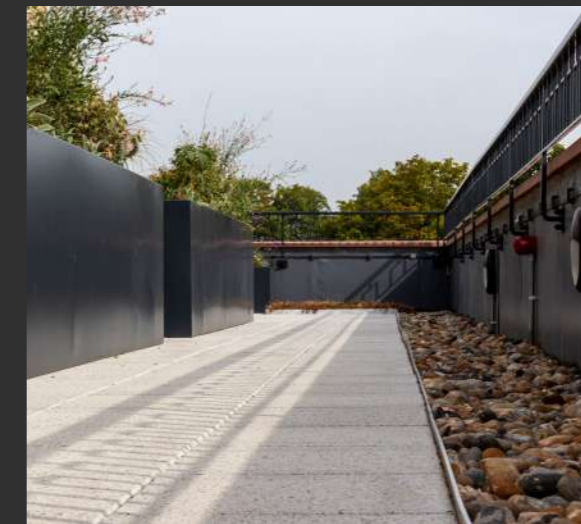



## LAYOUT NARRATIVE

The layout of surface materials tells a story. Whether it's a simple stack bond or a complex herringbone pattern, the way paving is arranged shapes how the terrace is read and used. Layout influences movement, scale, and how people interact with the space.

Large-format slabs (e.g. 1200x1200) or seamless finishes like resin-bound gravel can make small areas feel expansive and large areas less daunting. Smaller formats like 600x600 offer a balanced, familiar look that suits a wide

range of applications. Intricate patterns like box weave or staggered joints add sophistication and visual rhythm.

Designers should think about layout as a tool for storytelling; guiding the eye, defining zones, and creating transitions. It's not just about what materials are used, but how they're composed. A well-considered layout brings clarity and cohesion, helping the terrace feel intentional and inviting.

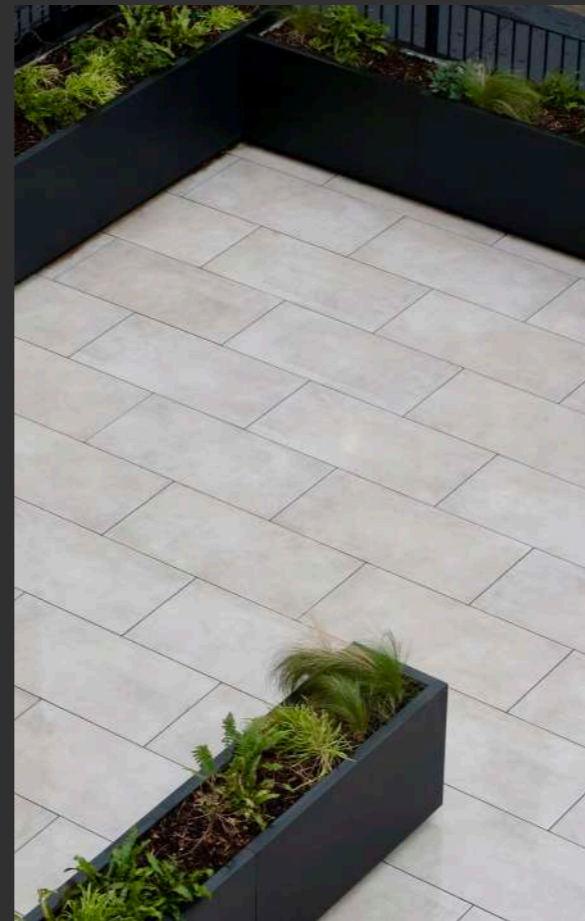

## LIGHTING ACCENTS

Lighting adds definition, depth, and atmosphere to a terrace, extending its usability well into the evening. It guides movement, emphasises focal points, and introduces contrast that enriches the overall composition. Integrated lighting, for example, whether set within steps, planters, or perimeter edges; enhances safety while maintaining a clean, unobtrusive visual language.

The quality and temperature of light influence how materials read after dark, with warm tones softening hard surfaces and cooler tones accentuating contemporary finishes. Subtle, concealed fittings preserve daytime clarity yet transform the terrace at night, creating an immersive and engaging environment. When thoughtfully positioned, lighting becomes a purposeful design layer that elevates both function and experience.

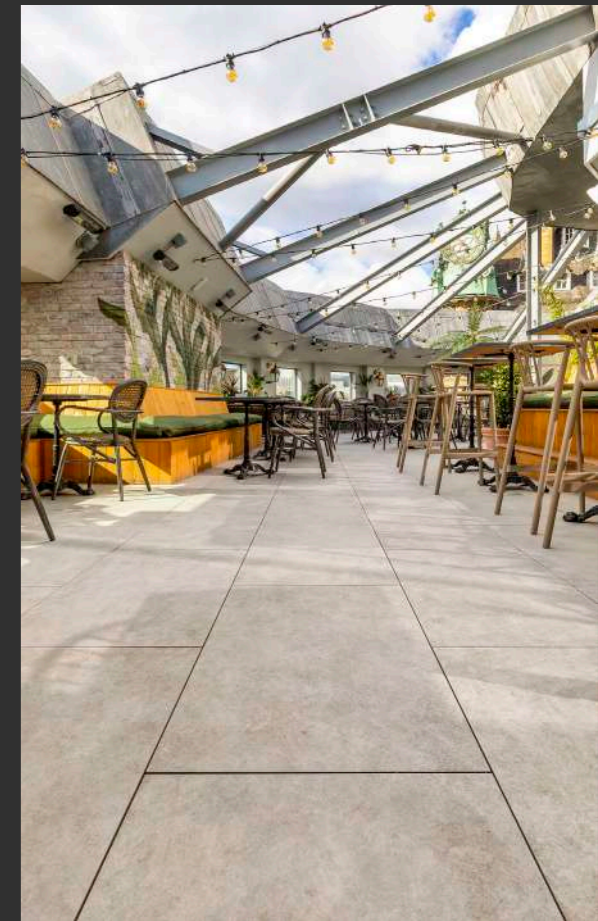

# FINISHES COLLECTION

With the surface language set, this is where ideas begin to feel real. Finishes and surfaces guide how a terrace is experienced, shaping light, movement and atmosphere. They tie the design together through tone, texture and structure, turning early concepts into a complete and achievable scheme.

Here you can step into the full RYNO finishes palette. Whether you are looking at paving, decking, seamless surfacing, planters or balustrades, every option is engineered for rooftop performance and gives you the freedom to shape the terrace in your own way.

Porcelain Pavers	32
Concrete Pavers	38
Natural Stone	42
Vitrified Composite Decking	44
Aluminium Decking	46
Composite Decking	48
Resin Bound Gravel	50
Wet Pour Rubber Crumb	52
Steel Planter Finishes	54
Timber Species - Furniture & Seating	56
Balustrades Finish's	58

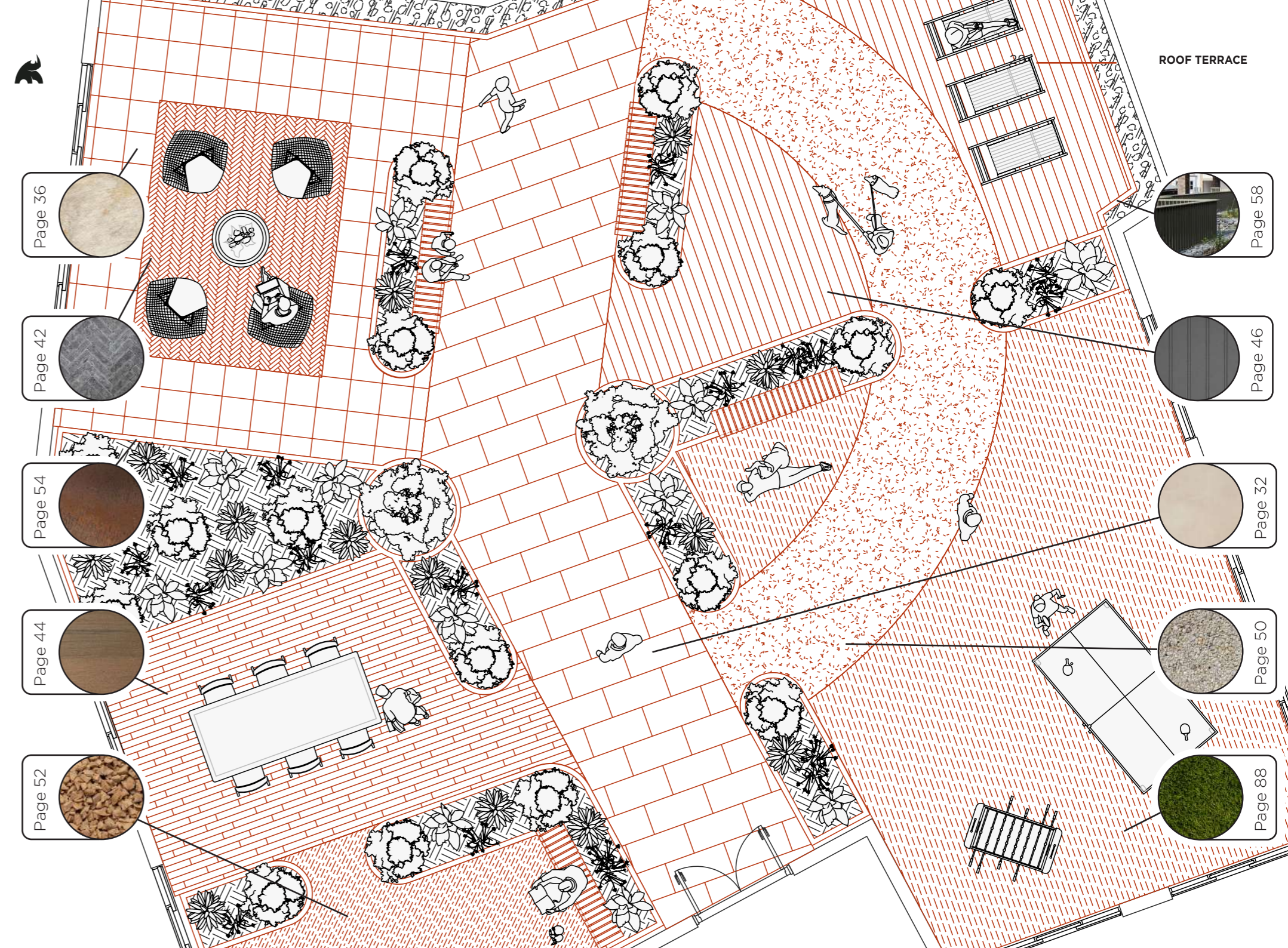
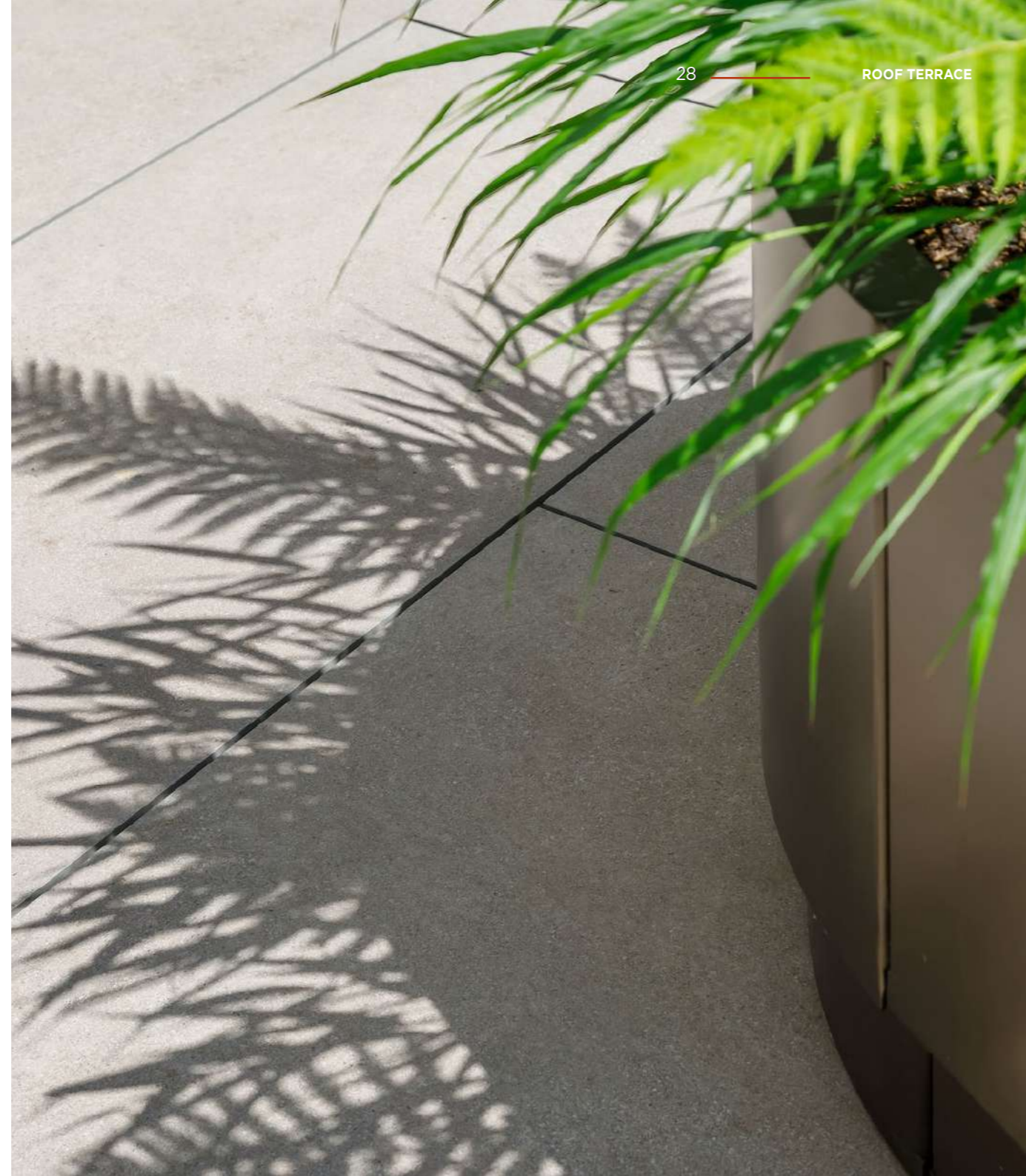

# TOCCO + CONCEPT

Tocco+ is our curated spectrum of colours and textures, created to bring harmony across every surface in a roof terrace scheme. It extends beyond porcelain to include resin bound gravel, wet pour rubber crumb and planter finishes, giving you a single, cohesive palette that works seamlessly across systems.

Think of it as a design tool rather than a product list. Tocco+ brings together our most versatile and most widely used finishes in one considered curation, helping you create coherence between tones, materials and surface types without limiting your creativity. It is a palette to inspire your own combinations, supporting you as you shape the terrace in your own way.

You can experience the full Tocco+ curation in our Clerkenwell studio, where seeing the finishes together makes it easier to compare, refine and make informed choices with confidence.



# PORCELAIN PAVING SIZES

Tile size has a significant influence on how a terrace feels. Larger formats create calm, expansive planes and help unify open areas, while smaller sizes introduce rhythm, structure and a more intimate visual scale. Our porcelain range is designed to give you this level of control, offering formats from classic proportions through to impressive 1200 x 1200 slabs that elevate even the most minimal layouts.

Each size brings its own design opportunities, allowing you to guide movement, define zones and set the overall character of the surface. And if your scheme calls for something more tailored, bespoke sizes and shapes are available on request, giving you even greater freedom to refine the aesthetic.

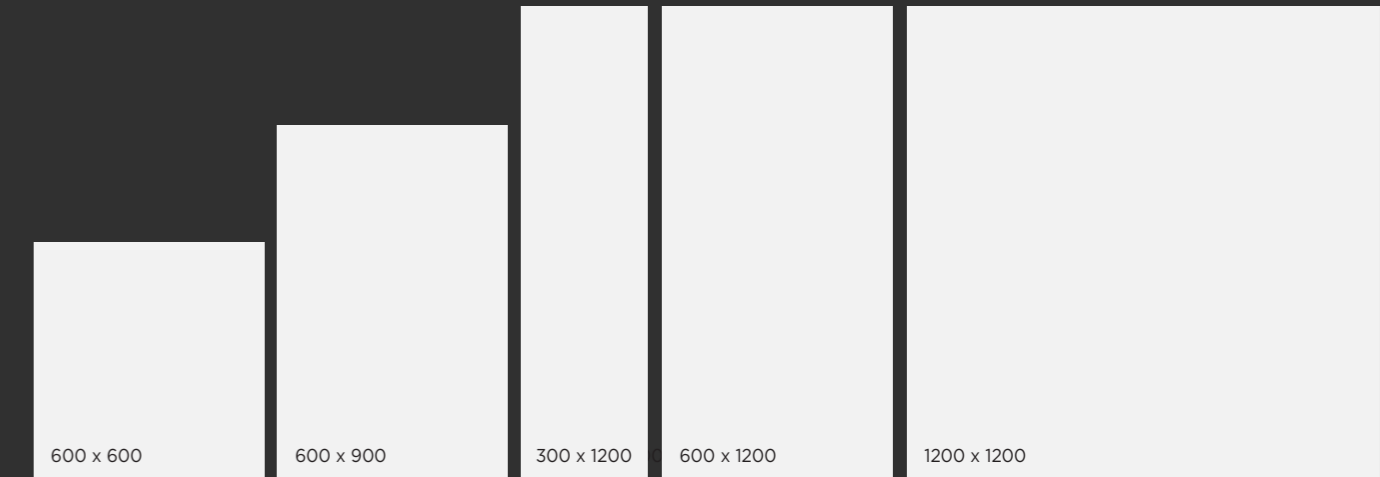

## TECHNICAL NOTE

All porcelain sizes listed are nominal. Actual working dimensions may vary slightly depending on the manufacturing process and the tile's calibre. For accurate specification, always refer to the product data sheet, which provides precise measurements and calibre information for each tile.

# PORCELAIN PAVING

## INSPIRED BY CONCRETE

Concrete aesthetics with refined consistency and a lighter touch. Porcelain brings clarity, precision and durability to the raw urban look. A modern surface that delivers strength without the heaviness of real concrete.

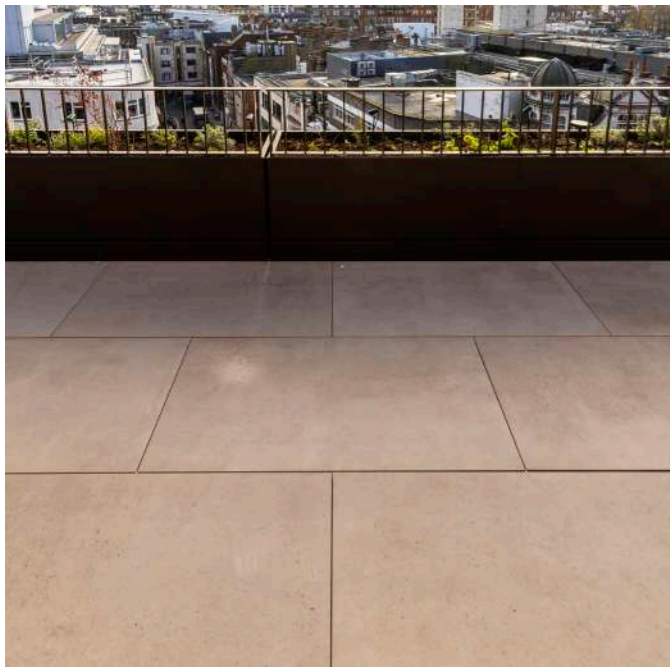

### CONCRETE & SCREED DESIGNS



Tocco Concrete Magma Grey



Tocco Concrete Lava Grey



Tocco Concrete Earth Beige



Tocco Concrete Coal Grey



Tocco Concrete Clay Taupe



Tocco Concrete Chalk White



Tocco Concrete Basalt Taupe



Tocco Concrete Ash Beige



Zynero Pearl Beige



Zynero Pearl Oyster Beige



Zynero Pearl Abalone Beige

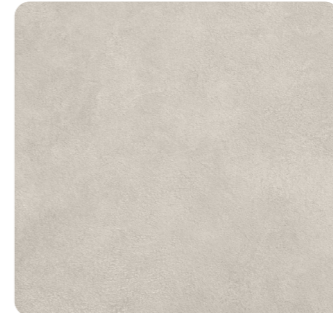

Tonaco Mist

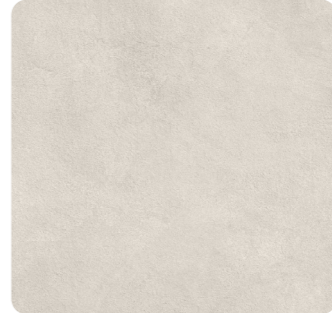

Tonaco Steam



Tonaco Foam



Tocco Canvas Mantle Grey



Tocco Canvas Lava Grey

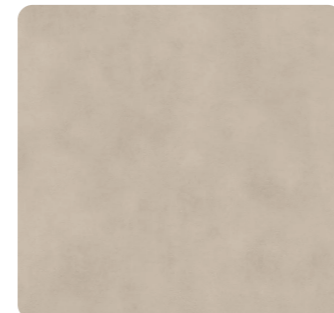

Tocco Canvas Stone Beige



Tocco Canvas Chalk White



Tocco Natural Chalk White



Tocco Natural Lava Grey



Tocco Natural Magma Grey



Tocco Natural Coal Grey



Quadro Argento Grey

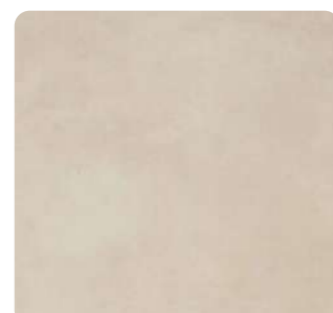

Quadro Crema Beige



Quadro Nero Anthracite



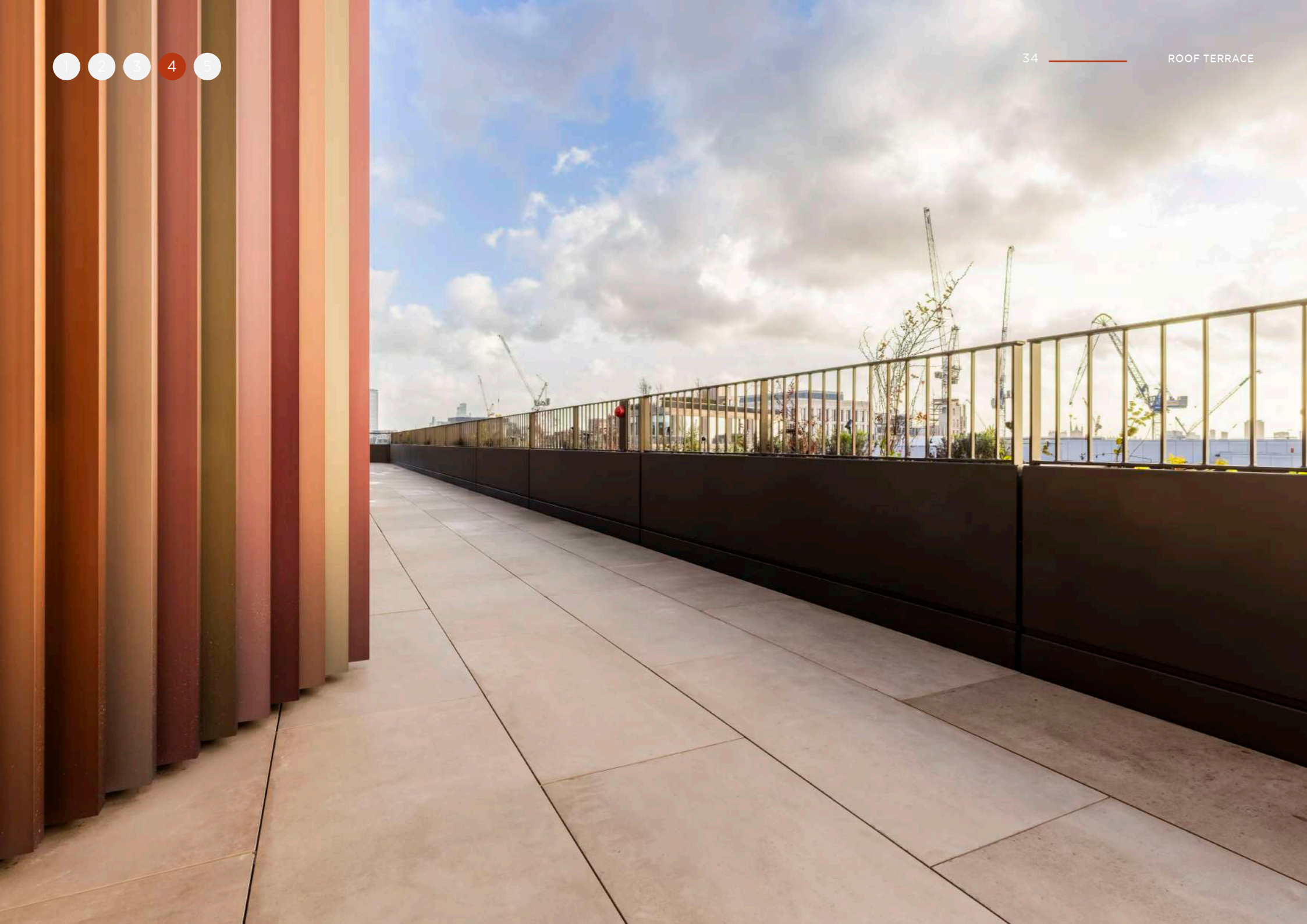

# PORCELAIN PAVING

## ROOTED IN WOOD

Timber warmth reinterpreted with the stability and longevity of porcelain. Natural grain and tone, without maintenance concerns or weathering shifts. A grounded, tactile surface ideal for softening structured terrace layouts.

### WOOD EFFECT



Albero Light Oak



Albero Silver Oak



Albero Warm Oak



Albero Pure Oak

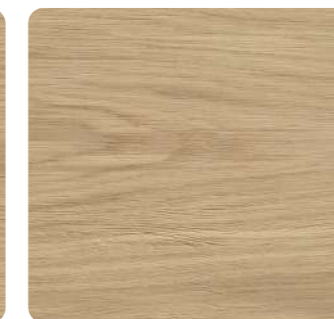

Albero Clean Oak



Grano Clear Wax Oak



Grano Teak Oiled Oak



Grano Tudor Waxed Oak



Grano Tung Oiled Oak

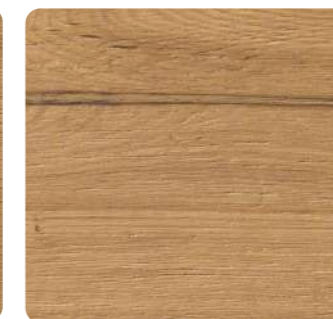

Legnoso Natural Oak



# PORCELAIN PAVING

## DERIVED FROM STONE

Stone character captured in a controlled, high-performance format. Porcelain delivers the nuance of mineral texture with superior resistance. A versatile surface that brings depth, calm and timeless architectural quality.



### STONE EFFECT



Dapello Jupiter Beige

Dapello Mercury Grey

Dapello Pluto Grey



Liddio Rock Black

Liddio Sand Beige

Liddio Shale Grey



Tocco Stone Lava Grey

Tocco Stone Fossil Grey

Tocco Stone Earth Beige



Dapello Saturn Beige

Liddio Diorite Beige

Liddio Pebble Anthracite

Tocco Core Mid Grey

Tocco Core Warm Beige

Tocco Core Cool Anthracite



Tocco Stone Coal Grey

Tocco Stone Chalk White

Tocco Stone Ash Beige

Cario Off White

Cario Warm Sand

Cario Bright Grey



Cario Deep Grey

Marbello Dusty Grey Marble

Marbello Snow White Marble

Marbello Hammered Carrara Grey

Marbello Hammered Calacatta Blanc

Marbello Hammered Calacatta Onyx



# CONCRETE PAVING

## THE ORDINARY TO THE REFINED

Concrete paving offers a versatile foundation for terrace design, spanning from robust, everyday surfaces to refined options with granite-like presence and elegant texture. It brings strength, authenticity and a grounded material quality to outdoor spaces, with finishes that range from practical and slip-resistant to beautifully detailed and architectural. With thoughtful selection, concrete becomes both a structural asset and a sophisticated aesthetic surface.

### CONCRETE



Adira Buff

Adira Natural

Adria Red



Piata Smooth Blue Grey

Piata Smooth Charcoal

Piata Smooth Cream



Piata Smooth Silver Grey

Piata Skimmed Blue Grey

Piata Skimmed Charcoal



Piata Skimmed Cream

Piata Skimmed Silver Grey

Piata Textured Blue Grey

Piata Textured Charcoal

Piata Textured Cream

Piata Textured Silver Grey



Liora Smooth Charcoal

Liora Smooth Light Granite

Liora Smooth Mid Grey

Liora Smooth Oatmeal

Liora Smooth Silver Grey

Liora Textured Charcoal Granite



Liora Textured Pink Granite

Liora Textured Charcoal

Liora Textured Light Cream

Liora Textured Indian Granite

Liora Textured Light Granite

Liora Textured Mid Grey



Liora Textured Oatmeal



Liora Textured Silver Grey



Nimra Buff



Nimra Natural



Hakura Buff



Hakura Charcoal



Hakura Natural



Galena Buff



Galena Natural



# NATURAL STONE PAVING AND SETTS

Natural stone brings a depth of texture and authentic material presence to terraces that only true geological surfaces can offer. From thoughtfully finished paving to coordinated steps and classic setts, stone introduces tonal richness, nuanced surface variation and enduring quality. Whether creating grounded transitions or patterned surfaces reminiscent of historic landscapes, this material family anchors a terrace with character and architectural poise.

## STONE



Desert Beige Limestone Paver - Etched



Quarry Grey Limestone Paver - Washed



Quarry Grey Limestone Paver - Etched



Lithos Grey Limestone Paver - Washed



Lithos Grey Limestone Paver - Etched



Petra Buff Sandstone Paver - Honed



Desert Beige Limestone Setts - Washed



Desert Beige Limestone Setts - Etched



Quarry Grey Limestone Setts - Washed



Quarry Grey Limestone Setts - Etched



Petra Buff Sandstone Setts - Honed



Canyon Grey Sandstone Setts - Tumbled



Fossil Buff Sandstone Setts - Tumbled

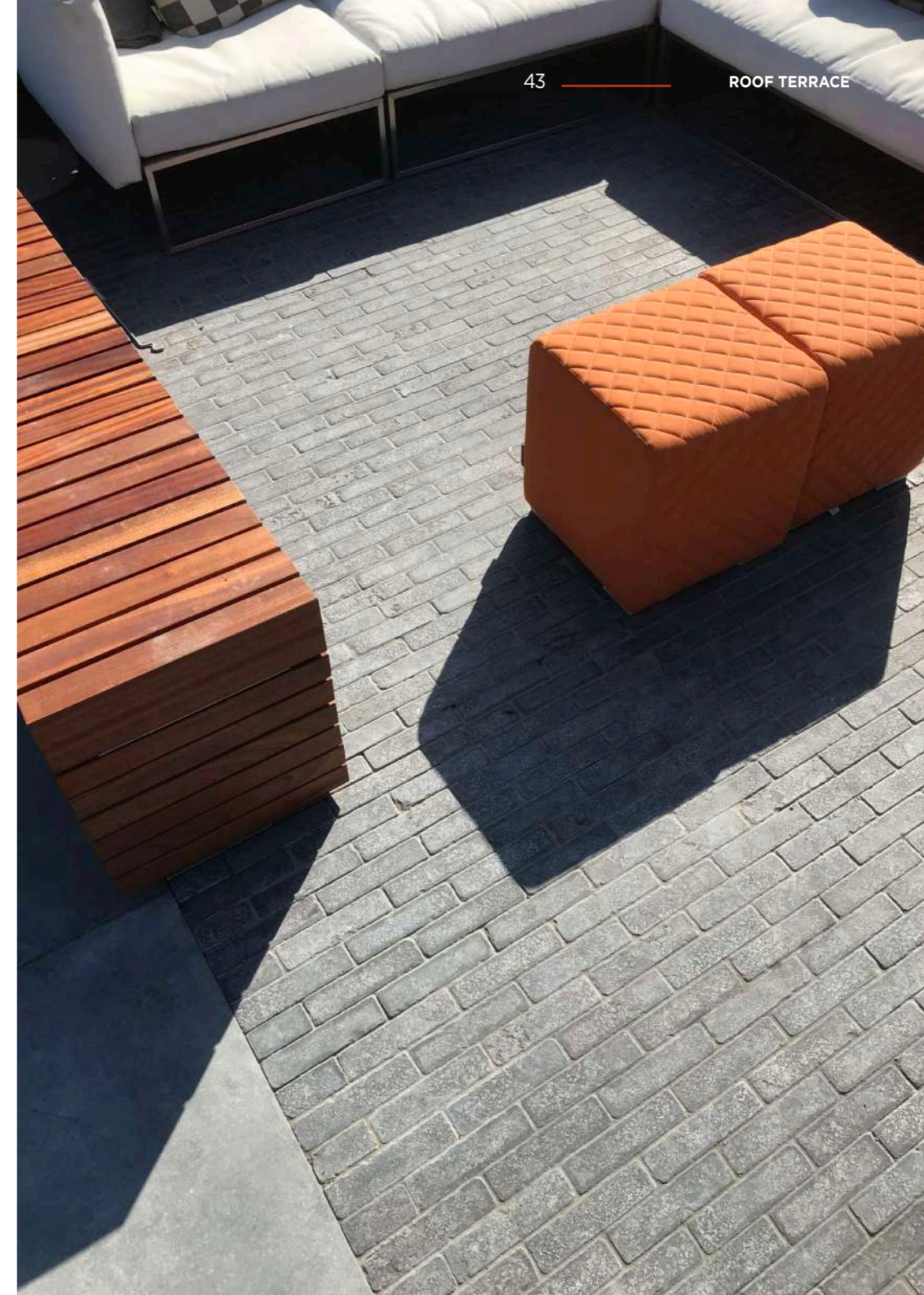

# VITRIFIED COMPOSITE DECKING

THE NON-COMBUSTIBLE DECKING THAT ACTUALLY LOOKS LIKE WOOD

Vitrified composite decking brings together technical reliability and a clean, contemporary look, offering a durable surface that performs consistently in demanding rooftop environments. With subtle tonal variation and a crisp, controlled finish, it gives designers the visual quality of more natural materials without the maintenance challenges.

This includes timber-inspired options that deliver the warmth of wood in a fully non-combustible format, providing a practical alternative where fire performance and aesthetics must work together. It is a smart choice for terraces that need long-term stability, low water absorption and a refined, modern appearance.

## VITRIFIED



African Greywood



Brazilian Walnut



Himalayan Birch



Sun-bleached Oak



White Poplar



# ALUMINIUM DECKING

## CLASSIC TEXTURED POWDER COATING COLOURS

Aluminium decking delivers exceptional durability, stability and long-term reliability, making it well suited to the technical demands of rooftop applications. Its lightweight, fully non-combustible profile ensures confident compliance without adding unnecessary load to the build-up. With strong slip resistance and consistent dimensional accuracy, aluminium provides a dependable surface that performs predictably over time. It is a straightforward, high-performance choice for projects where safety, resilience and system integrity are the priority.

### ALUMINIUM

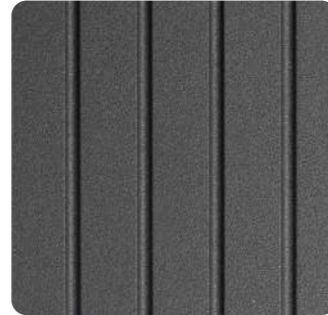

RAL 7016 - Anthracite Grey

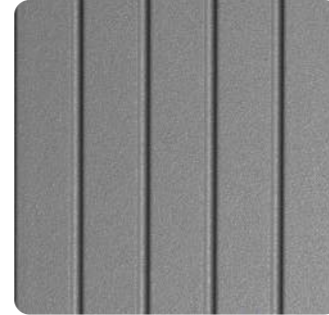

RAL 7037 - Dusty Grey

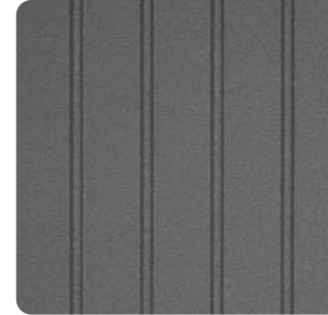

RAL 7039 - Quartz Grey

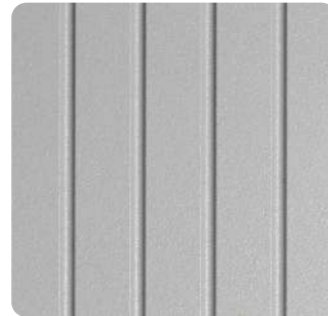

RAL 7040 - Window Grey



RAL 8014 - Sepia Brown



RAL 8019 - Grey Brown



Any standard RAL (POA)



# COMPOSITE DECKING

Composite decking offers a timber-inspired look for rooftop projects where fire requirements allow. It provides consistent colour, reduced weathering and an inviting underfoot feel with engineered resilience.



## COMPOSITE

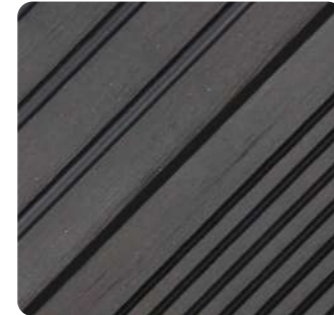

Classic Charcoal

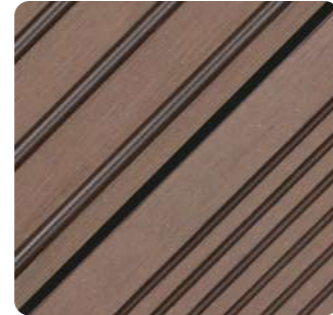

Classic Chocolate



Classic Sand

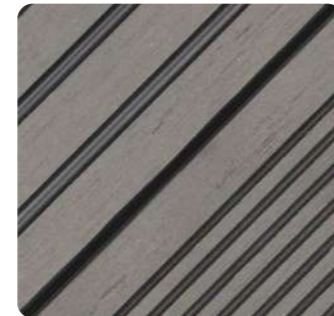

Classic Slate

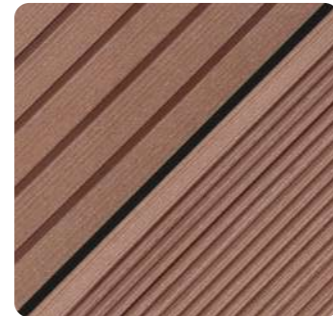

Performance Dawn



Performance Dusk



Performance Midnight

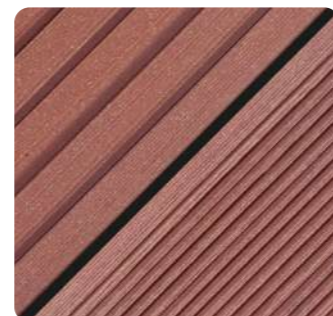

Performance Noon



Performance Twilight



Signature Ebony



Signature Mahogany



Signature Silver Birch



Signature Sycamore



Signature Teak



Signature Willow

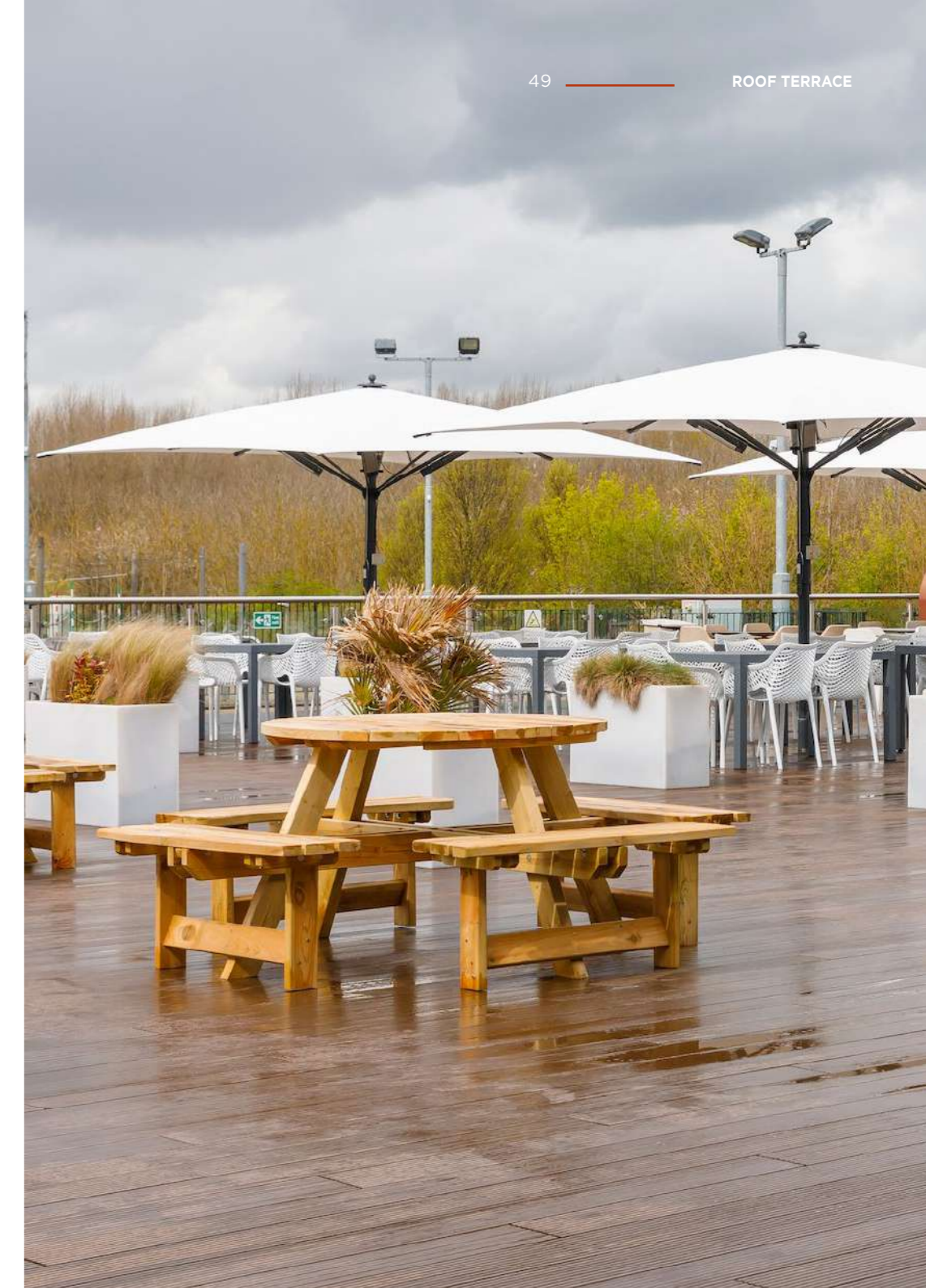

# RESIN BOUND GRAVEL

## SEAMLESS, PERMEABLE AND REFINED

Resin bound gravel creates a seamless, free-draining surface with a natural yet highly controlled character. It delivers excellent permeability and long-term stability, making it ideal for terraces that need smooth transitions and clean detailing without visible joints. With a curated choice of blends and tones, it offers a consistent, contemporary finish that brings texture and warmth to rooftop environments. The complete system is tested to B<sub>ROOF</sub>(t4), supporting confident specification at height.



### GRAVEL



Flint



Granite



Diorite



Sandstone



Clay



Pebble



Pumice



Quartz



Breccia



Schist



Pearl



Shale



Portland

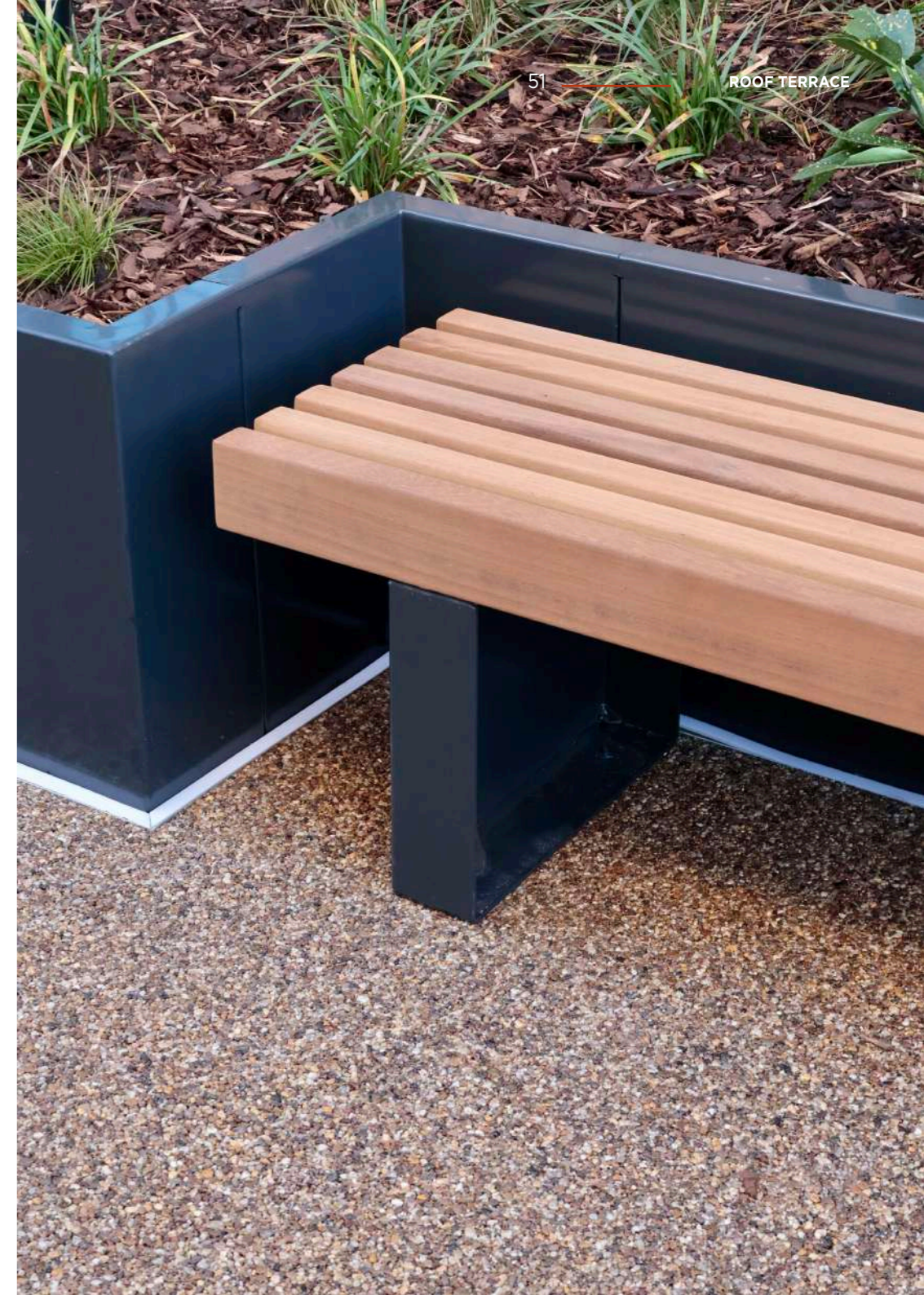



# WET POUR RUBBER CRUMB

## SURFACING FOR ROOFTOP PLAY AND SPORTS AREAS.

Wet pour rubber crumb provides a continuous, impact-absorbing surface that is well suited to active or high-movement areas on rooftop terraces. Its seamless application creates smooth transitions and a comfortable underfoot feel, delivering a softer alternative to harder surface finishes without compromising durability. Available in a curated palette of colours, it offers a practical, resilient option for leisure-focused or family-oriented spaces. The complete system is tested to B<sub>ROOF</sub>(t4), ensuring confidence and compliance in elevated settings.

### NATURAL COLOURS



Chalk Natural



Shell Natural



Clay Natural



Sand Natural



Wood Natural



Copper Natural



Chestnut Natural



Forest Natural



Meadow Natural



Ash Natural



Dust Natural



Charcoal Natural

### BRIGHT COLOURS



Pink Bright



Lilac Bright



Orange Bright



Green Bright



Yellow Bright



Red Bright



Turquoise Bright



Aqua Bright



Blue Bright



Cobalt Bright



# STEEL PLANTER FINISHES

## MATERIALITY WITH A CONSIDERED PALETTE

Planter finishes help bring clarity and material cohesion to the vertical elements of a terrace, allowing these features to sit comfortably within the wider design. From raw steel tones to refined metallic coatings and classic architectural colours, the palette offers a structured yet versatile set of options to support your chosen aesthetic. Each finish is durable, colour-stable and engineered for rooftop performance, with bespoke options available for schemes that need a more tailored expression.

### STEEL & COATINGS



Blackened Steel



Corten Steel



Marbled Steel



Dark Metallic Bronze Coating



Mid Metallic Bronze Coating



Corten Metallic Coating



RAL 7016 - Anthracite Grey Semi-Gloss

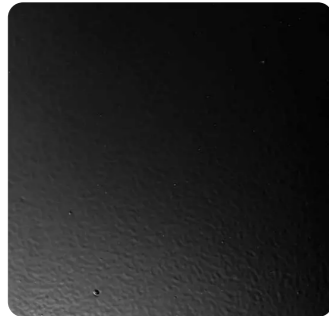

RAL 9005 - Jet Black Semi-Gloss



RAL 7032 - Pebble Grey Semi-Gloss



RAL 7021 - Black Grey Semi-Gloss

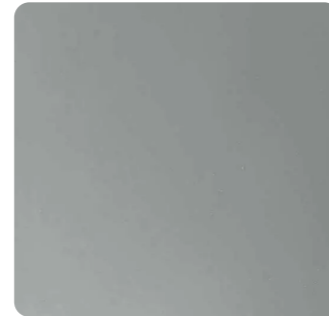

RAL 7045 - Telegrey Semi-Gloss



Any standard RAL (POA)



# TIMBER SPECIES

## FURNITURE + SEATING

Timber brings natural warmth and tactility to seating and cladding, adding a softer, more human touch to rooftop spaces. Our three most popular species — Iroko, Sapele and Douglas Fir — each offer their own grain, tone and character, allowing you to choose the expression that best aligns with your material palette. All are well suited to outdoor environments, ageing gracefully over time and supporting designs that seek comfort, durability and a grounded, natural aesthetic. Bespoke specifications can also be explored where a more tailored look or performance requirement is needed.

### TIMBER



Iroko



Sapele



Douglas Fir



Others available on request



# BALUSTRADE FINISHES

## CLASSIC ALUMINIUM POWDER COATING COLOURS

Balustrade finishes can align seamlessly with the wider terrace palette, using the same powder-coated colours offered across our aluminium systems. This creates a coherent, architectural look that carries through both horizontal and vertical elements. For projects that need a more specific tone or a precise design match, any RAL colour can be specified, giving you full control over how the balustrade integrates into the scheme.

### ALUMINIUM

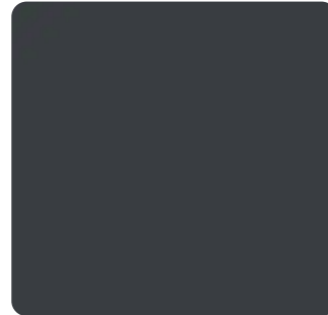

RAL 7016 - Anthracite Grey



RAL 7037 - Dusty Grey



RAL 7039 - Quartz Grey



RAL 7040 - Window Grey

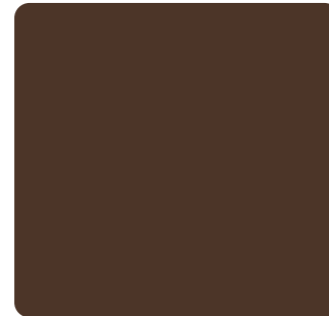

RAL 8014 - Sepia Brown

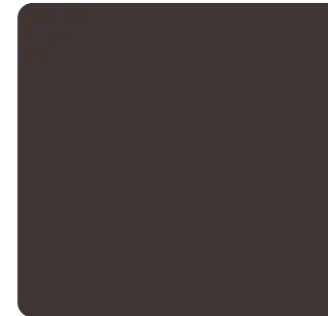

RAL 8019 - Grey Brown



Any standard RAL (POA)





## STEP 5

# BUILD-UP THE SUPPORT SYSTEM

Thinking holistically matters - it's not just the build-up, but how each system and material works together to form a complete, integrated solution. Get this right early to avoid coordination headaches later.



# THE COMPLETE INTEGRATED SYSTEM

A roof terrace performs as a single environment, but only when the layers beneath it work together. From the structural deck and waterproofing to supports, rails and finishes, each component affects drainage, loading, movement, fire performance and durability. When considered as one continuous build up, the terrace behaves predictably, installation is clearer, and the design intent is maintained.

The images on the right show how the assembly connects from substrate to surface, providing a clear starting point for design and coordination.

Paving	66
Decking	74
Surfacing	82
Planters	90
Balustrades	98
Pedestal Paving Systems	98

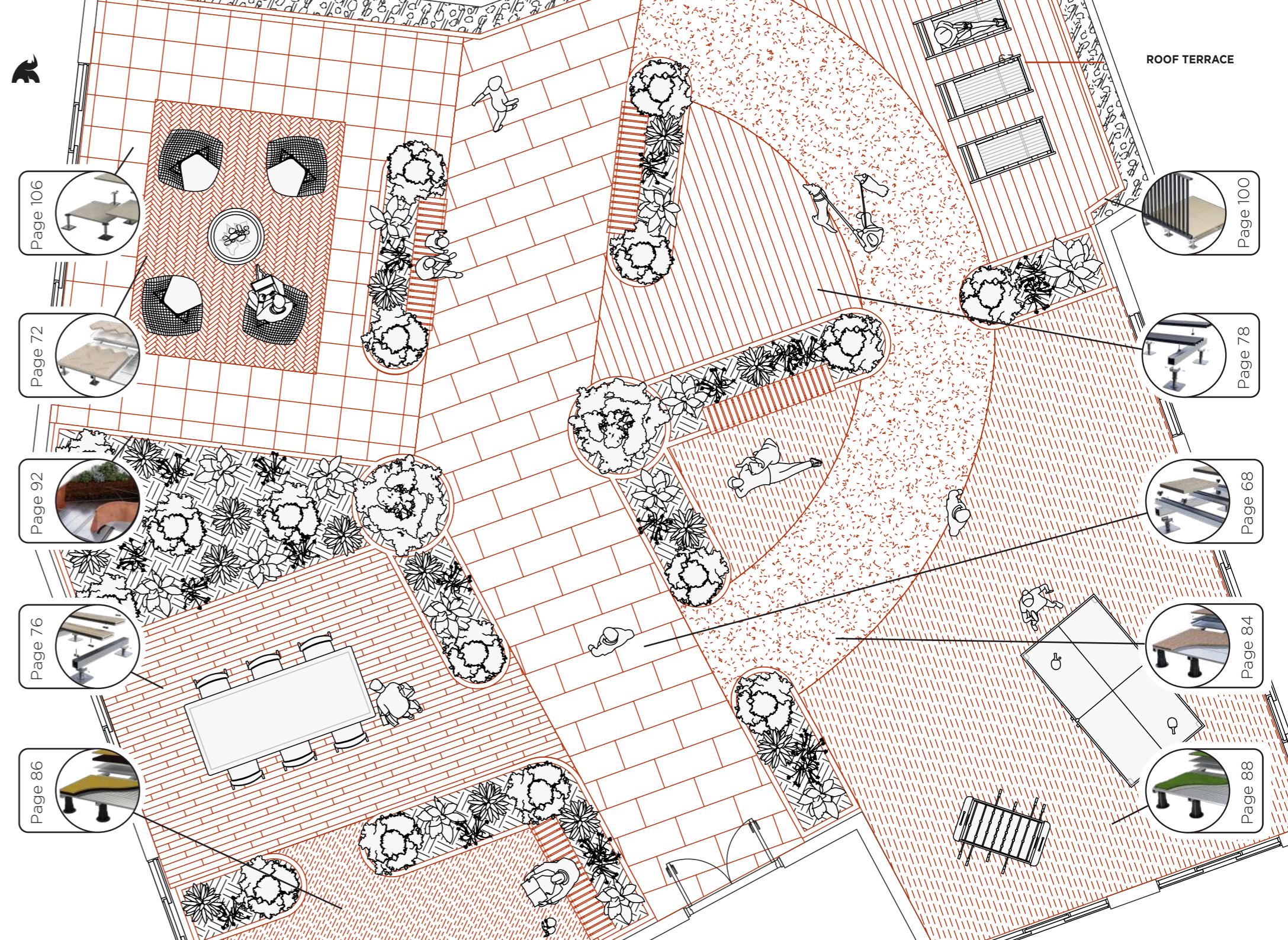



# THREE FACTS WORTH KNOWING

## 01. MOST TERRACE FAILURES START BELOW THE SURFACE

Issues such as water retention, membrane stress and movement typically originate in the supporting layers, not the visible finish.

## 02. INTERFACES ARE THE HIGHEST-RISK POINTS IN A TERRACE BUILD-UP

Every junction between different components or trades introduces additional coordination considerations and potential performance variability.

## 03. PERFORMANCE IS GOVERNED BY THE WHOLE BUILD-UP

Fire behaviour, drainage flow and wind uplift resistance depend on how all layers operate together as an assembly, rather than the properties of isolated products.

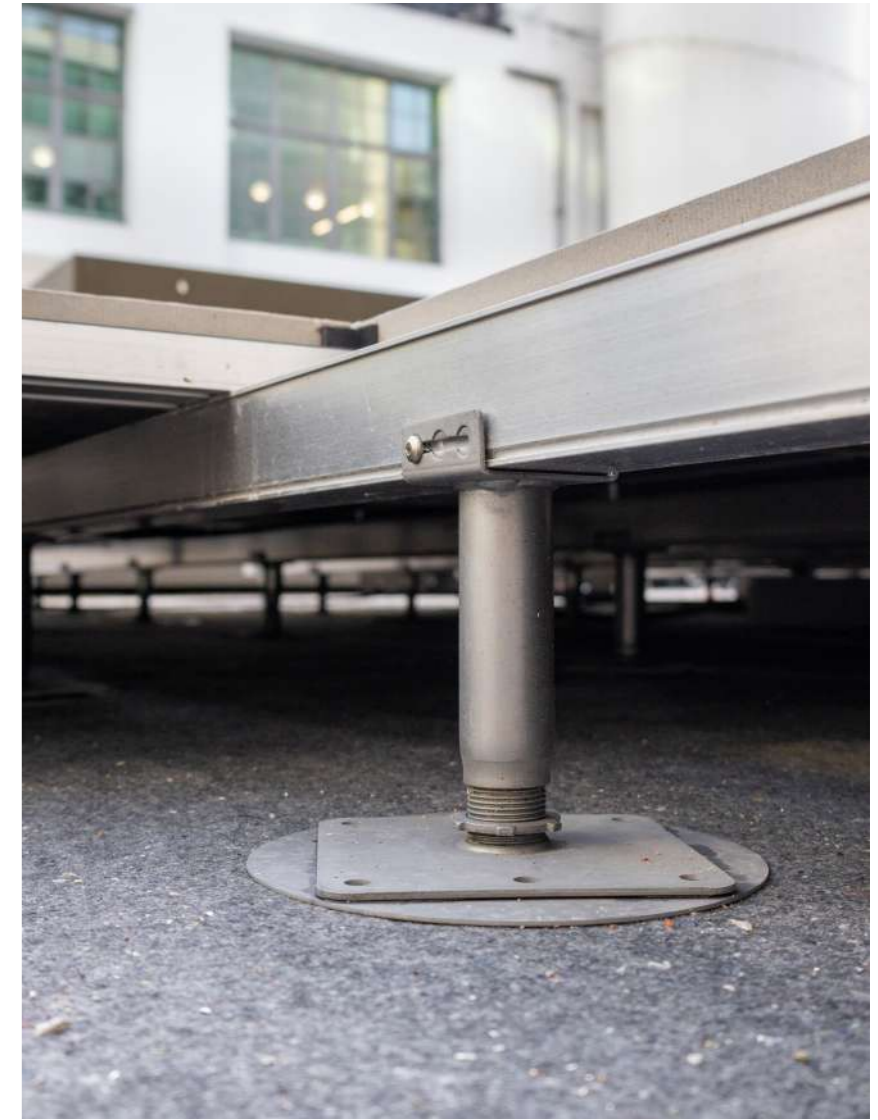



# INTEGRATED PAVING SYSTEMS

Integrated paving systems create stable, rigid surfaces that connect seamlessly with surrounding finishes. They support cohesive terrace layouts while unlocking greater design freedom, allowing architects to explore more creative and coordinated outdoor spaces.



# TERRASMART RAIL PAVING

## PREMIUM, VERSATILE PAVING SYSTEM FOR WATERPROOFED SUBSTRATES

TerraSmart Rail is the ultimate raised paving system, locking pavers together with its unique lattice framework creating an incredibly solid platform, suitable for both intricate formats and high-load, heavily foot-trafficked applications.

- Unbelievably solid
- Non-combustible, A1 fire rated
- Enables unrivalled range of paving formats and designs
- Suited to high foot traffic environments
- Caters to complex edge details
- Wind up-lift solutions available

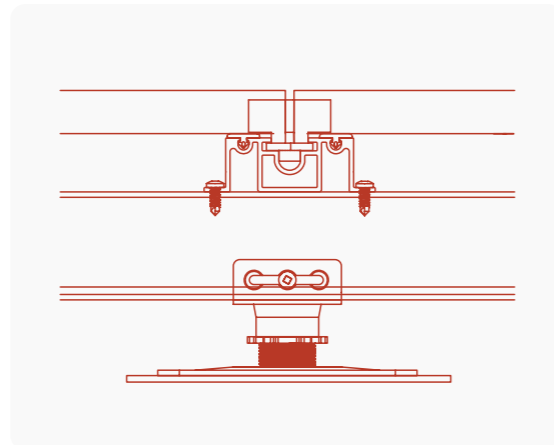

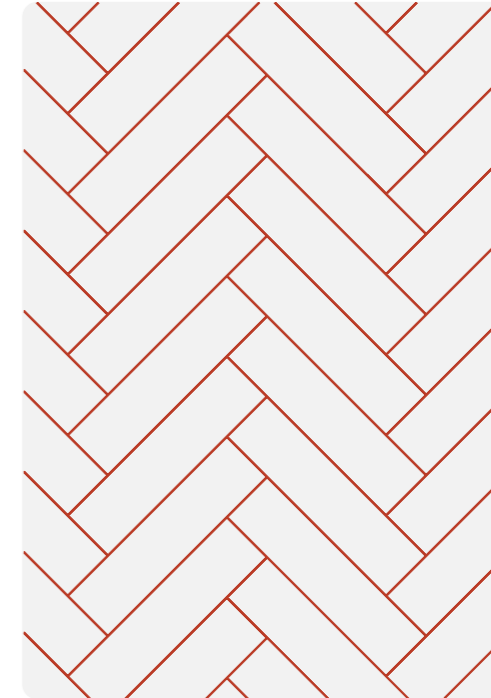
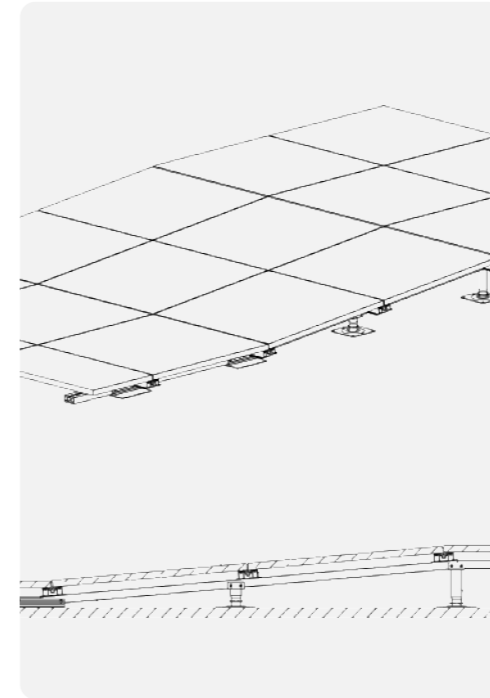
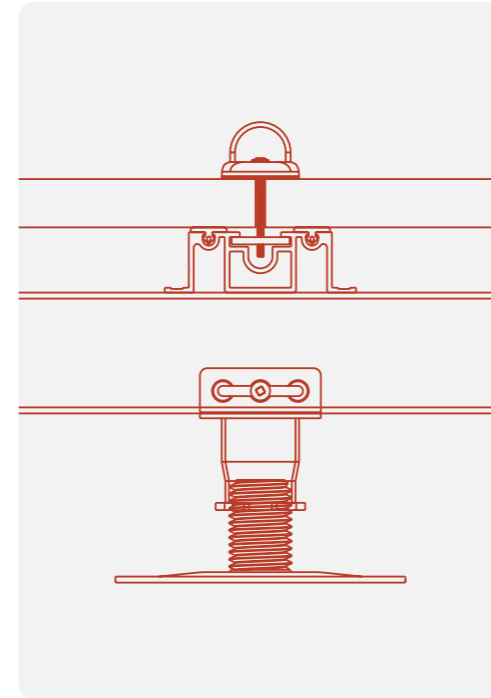
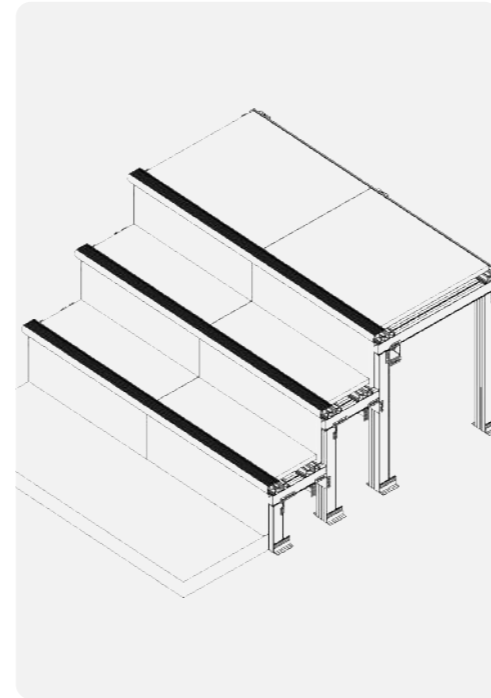
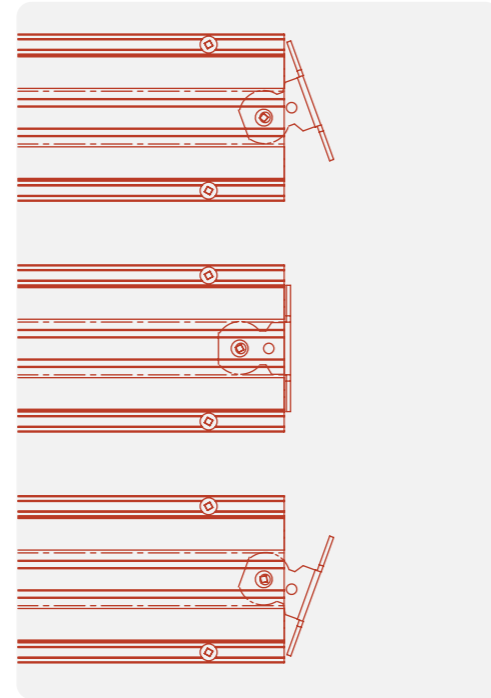
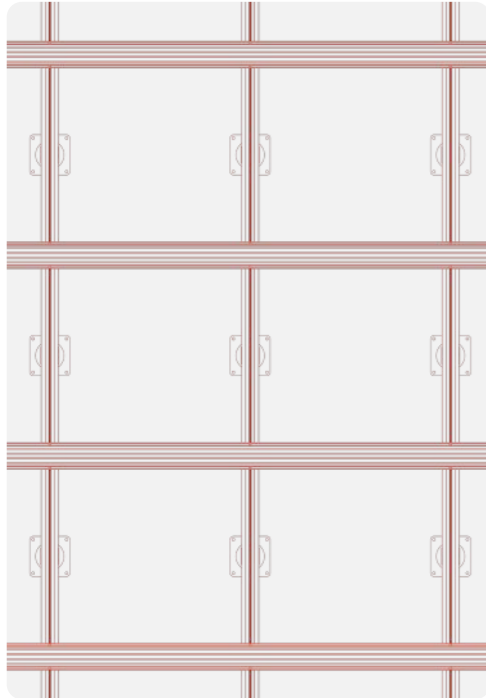

**LOCKED IN LATTICE FRAME**

The interlocking lattice rail frame locks pavers together, preventing movement and reducing the risk of gaps opening over time. This unified structure also enables the system to be designed to higher loadings where required.

**WIND LOAD MITIGATED**

The mechanically connected rail and paving assembly helps mitigate wind load across the surface. By distributing forces through the system rather than individual pavers, stability is maintained on exposed roof terraces.

**ANGULAR EDGE DETAIL SORTED**

An adjustable end stop with a ball-and-socket joint allows precise angular alignment at edges. This enables clean perimeter detailing while maintaining consistent support beneath the paving.

**STEP THINGS UP**

Integrated step solutions allow changes in level to be formed within the same system build-up. This supports clear, consistent detailing across split-level roof terrace designs.

**FURNITURE ANCHORED**

A dedicated furniture anchor enables secure fixing of terrace furniture and features. This allows elements to be restrained safely without penetrating or compromising the waterproofing layer.

**RAMP IT UP**

The system can be configured to form gentle ramps where required. This level of control cannot be achieved using pedestal-only solutions.

**CREATIVITY UNLOCKED**

Supports a wide range of paving layouts, from simple stretcher bond through to herringbone, basketweave and patio patterns. This gives designers greater freedom to express layout and geometry across the terrace.

**SMALL CUTS SUPPORTED**

Aluminium baseboards provide continuous structural support beneath small cuts and infill pieces. They can be cut and trimmed on-site without compromising performance, offering maximum detailing flexibility.

# TERRASMART NATURAL STONE SETTS

## RAISED, NATURAL STONE SETTS SYSTEM BRINGING NATURAL AESTHETICS TO ROOF TERRACES

The TerraSmart Natural Stone Setts system allows you to bring the classic look of traditional landscaped parks and historic gardens to your roof terrace. This raised system enables the use of authentic natural stone cobbles and setts, creating a timeless and elegant outdoor space. The raised design allows for efficient drainage, protection of the roof membrane, and lightweight height flexibility.

- Raised system design
- Clean heritage aesthetic
- Multiple sett layouts
- 7 finish options across 5 stone types
- Finishes paired with our Natural Stone Paving
- Integrates with other systems

\*EPDs available for components of this system.

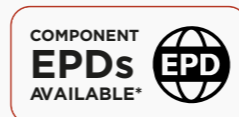
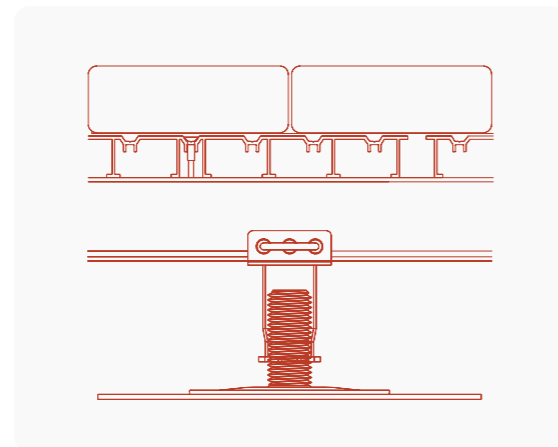

### GROUNDING, SOLID FEEL

The mass and arrangement of natural stone setts create a surface that feels solid and permanent underfoot. This delivers a grounded, grand character more commonly associated with parks, courtyards and historic gardens.

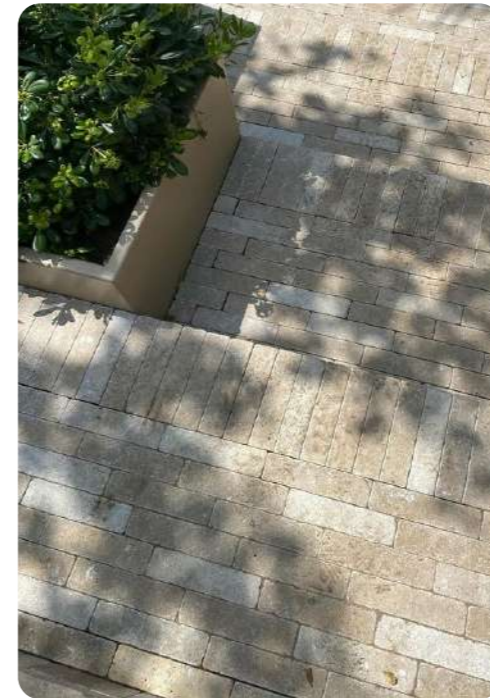

### TRADITIONAL SETT LAYOUTS

Supports a wide range of classic sett patterns, including coursed, random and herringbone layouts. This allows designers to recreate traditional landscape compositions on raised roof terrace applications.

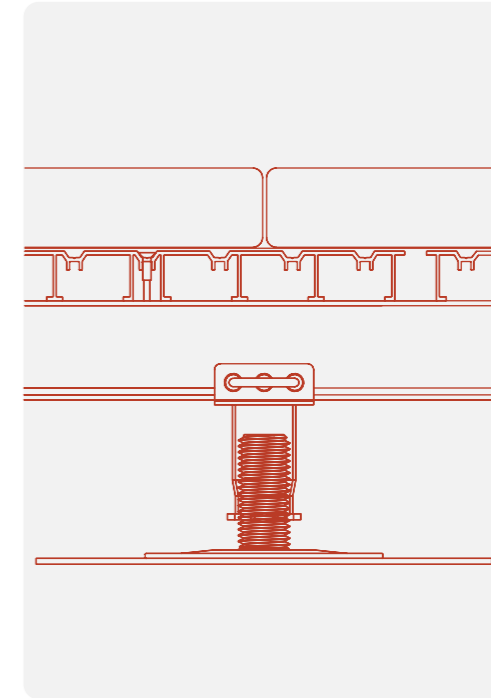

### LIGHTWEIGHT RAISED BUILD-UP

Delivers the visual mass of traditional stone in a raised system that is lighter than a bonded build-up. Ideal for roof structures with limited load allowances.



### AUTHENTIC NATURAL STONE

Designed to accommodate genuine natural stone setts rather than replicas or lightweight alternatives. This ensures material authenticity, natural variation and a timeless finish suitable for premium roof terraces.



# DECKING SYSTEMS

Our decking systems deliver flexible, adjustable surfaces that flow across complex layouts and integrate with other surfaces. With a wide choice of finishes and compliance options, they support versatile terrace designs that adapt easily to different project requirements.



# TERRASMART VITRIFIED COMPOSITE DECKING

**NON-COMBUSTIBLE, WOOD EFFECT DECKING  
SYSTEM FOR WATERPROOFED SUBSTRATES**

TerraSmart Vitrified Composite™ Decking is the perfect choice for terraces and balconies, offering both stunning aesthetics and long-lasting durability. Incredibly realistic, yet entirely fireproof.

- Stunningly realistic hard-wood effect
- Entirely resistant to stain, fade or scratches
- Completely stable, zero expansion or contraction
- Natural edge bevel
- Non-combustible, A1 fire rated
- Very low maintenance
- Built in wind uplift restraint
- 30-year warranty, 60-year design life\*  
\*Valid when installed as a complete RYNO system

\*EPDs available for components of this system.

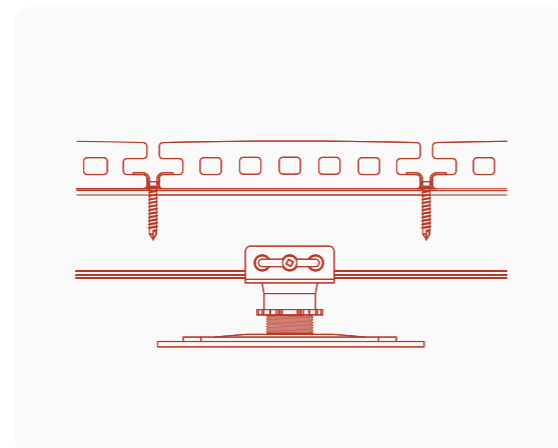

## NATURAL BEVEL EDGE

A subtle natural bevel edge replicates the softened profile of real timber boards. This avoids the sharp, rectified appearance common with porcelain tiles.

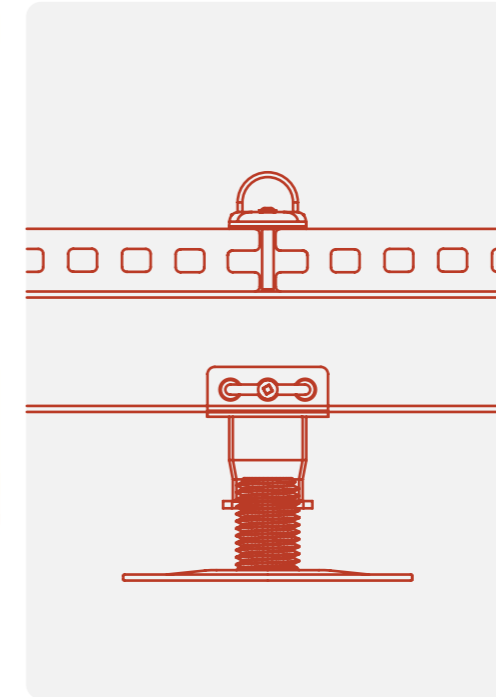

## FURNITURE ANCHORED

A discreet furniture anchor fits neatly between decking boards. This allows furniture and features to be securely fixed while maintaining a clean, timber-style surface.



## ACTUALLY LOOKS LIKE WOOD

Surface texture and tonal variation closely replicate the appearance of natural timber. This allows a timber aesthetic to be achieved where fire performance requirements restrict the use of real wood.

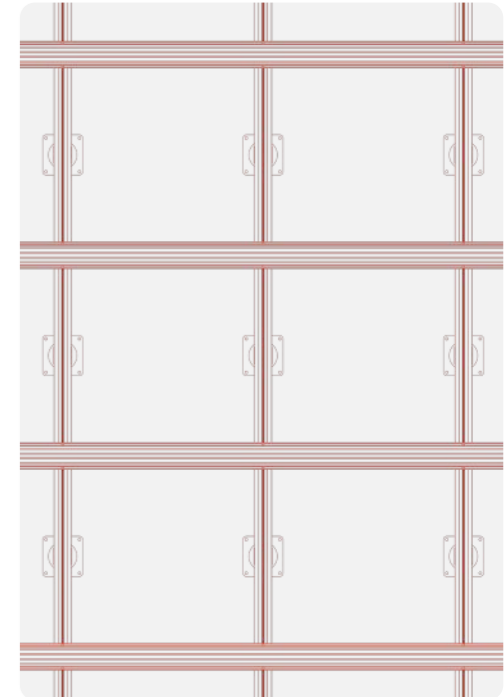

## LATTICE FRAME OPTION

An optional lattice frame can be introduced beneath the decking where required. This enables wider pedestal spacing or integration with other Ryno lattice-based systems.

# TERRASMART ALUMINIUM DECKING

## THE DECKING SYSTEM WITH UNPARALLELED VERSATILITY

TerraSmart Aluminium is a non-combustible aluminium decking system designed to be installed on waterproofed balconies, terraces, and walkways. A broad range of decking board and component combinations are available to achieve the desired finish, height build-up and performance standard.

- Non-combustible, class A fire rated
- Industry leading install speed
- 6 standard colours (any RAL colour available on additional lead-time)
- Long-lasting, with excellent scratch and wear resistance
- Wind uplift options available
- 30-year warranty, 60-year design life\*  
\*Valid when installed as a complete RYNO system

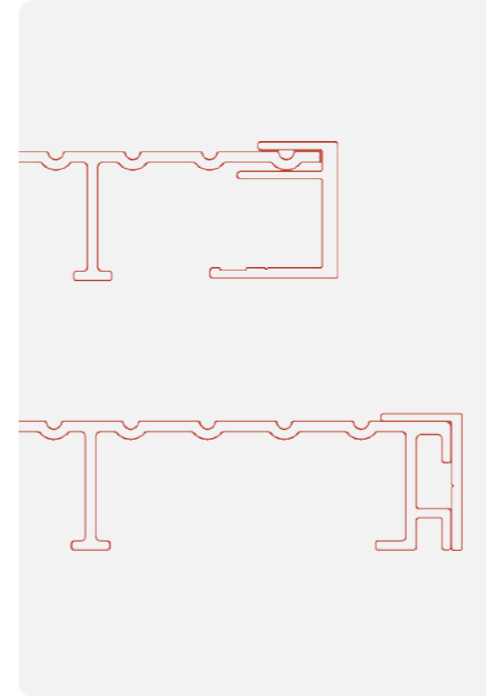
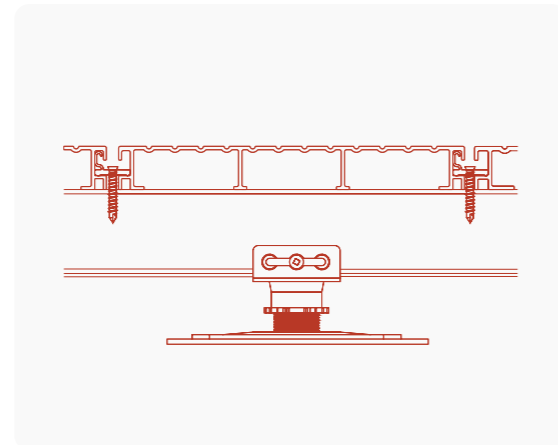

### EDGE DETAILS CONSIDERED

A range of edge profiles ensures clean, supported board terminations. E profiles support cut boards, while L profiles provide a neat finish along board ends and perimeters, maintaining a consistent deck edge detail.



### FURNITURE ANCHORED

A discreet furniture anchor integrates directly within the decking layout. This enables secure fixing of furniture and features without disrupting the finished surface.

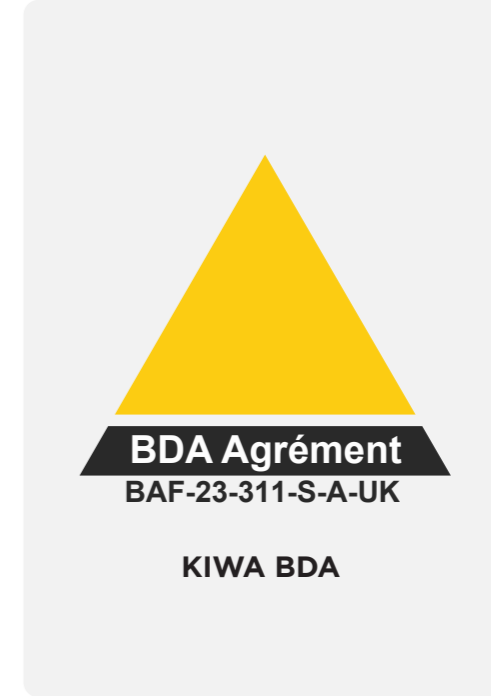

### UNMATCHED ACCREDITATION

The system has achieved BDA Agrément, independently verifying performance and compliance. This provides added confidence for specification on safety-critical and high-performance projects.

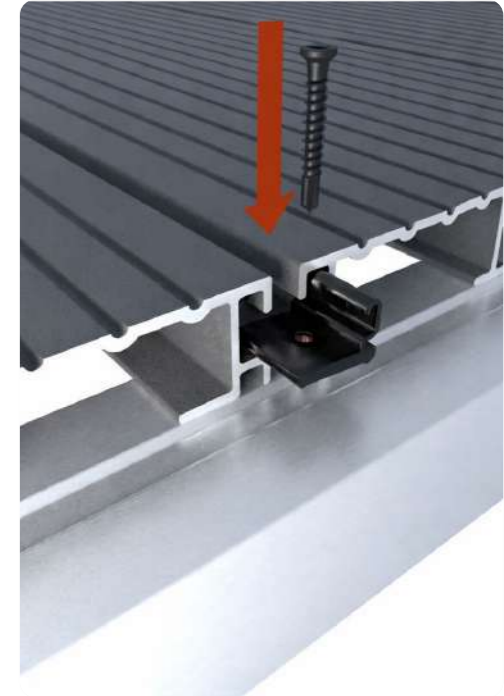

### RAPID INSTALLATION

The patented Alu-clip allows boards to be fixed without drilling through multiple aluminium layers. This clever, yet straightforward fixing detail significantly reduces installation time on site.

# TERRASMART COMPOSITE DECKING SYSTEM

## WOOD-PLASTIC COMPOSITE DECKING SYSTEM FOR OUTDOOR SPACES

TerraSmart Composite combines premium wood-polymer composite (WPC) decking boards with the high-performance substructure systems RYNO are so well-known for, to create a beautiful deck with incredible longevity. Manufactured from sustainably farmed FSC wood fibres, our composite decking boards provide the timeless look of wood decking without any of the associated downsides.

- Ideal for communal areas, public spaces, commercial and low-rise developments
- Decking boards available in wide range of beautiful finishes
- Class B & C fire rated options available
- Simple design enabling easy installation
- Fully height-adjustable support system

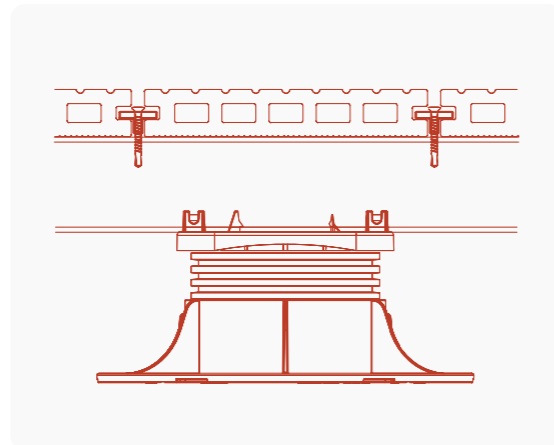

**10** YEAR  
SYSTEM  
WARRANTY

COMPONENT  
**EPDs**  
AVAILABLE\*



REACTION TO FIRE  
**B&C**  
OPTIONS





# SURFACING SYSTEMS

Surfacing systems enable seamless finishes typically found at ground level, including artificial grass, resin bound gravel and rubber surfaces. Designed specifically for roof terraces, they support fire compliant design as a lightweight, accessible alternative to traditional build ups, integrating seamlessly with other systems.



# TERRASMART RESIN BOUND GRAVEL

## RAISED, LIGHTWEIGHT FLOORING SYSTEM WITH A SEAMLESS RESIN BOUND AGGREGATE FINISH

The TerraSmart Resin Bound Flooring System offers a sleek, jointless appearance thanks to its permeable top surface, making it the perfect choice for walkways and communal areas on roof terraces. The lightweight, adjustable raised system, featuring the Baseboard, is designed to seamlessly integrate with TerraSmart Rail Paving Systems and Planter Systems.

- Lightweight system
- Completely permeable
- Select from 14 colourways
- Seamless appearance
- Very low maintenance
- Integrates with other systems

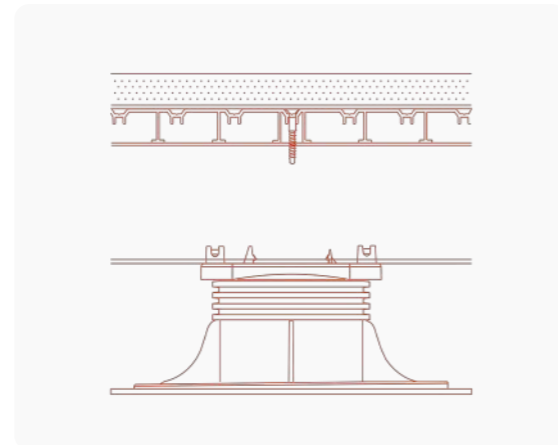

<b>A1</b> REACTION TO FIRE		<b>B<sub>ROOF</sub>(t4)</b>	
<b>LOW</b> SLIP RISK		<b>COMPONENT</b> <b>EPDs</b> AVAILABLE*	
<b>10</b> YEAR SYSTEM WARRANTY			

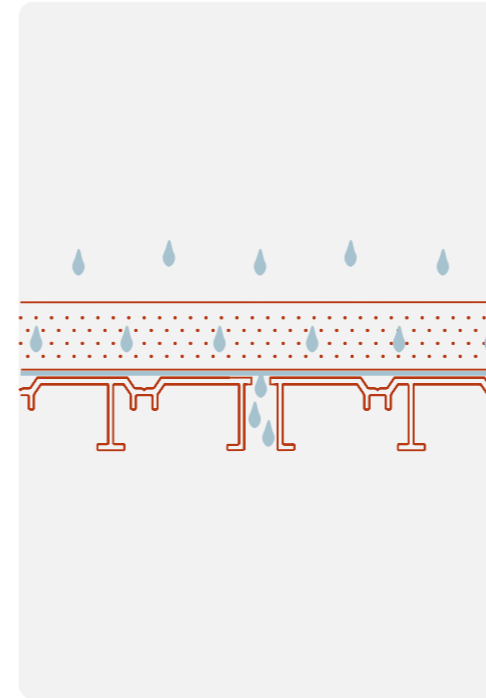

### PERMEABLE SURFACE

The resin bound aggregate surface is fully permeable, allowing water to drain through the build-up. This supports effective surface water management and reduces the risk of standing water.

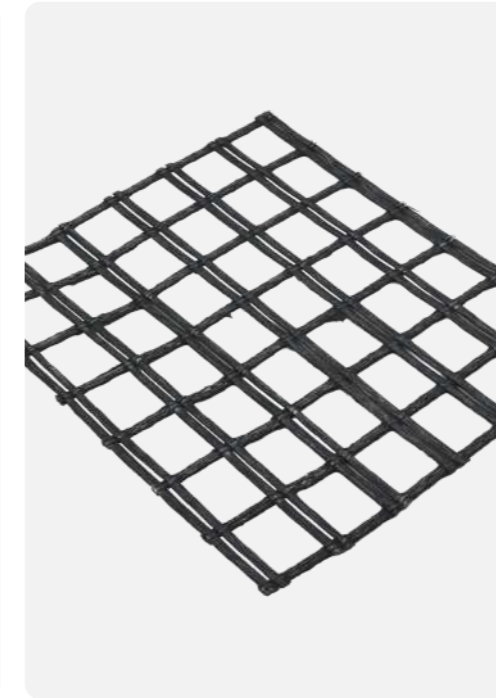

### STABILISATION BUILT IN

The system incorporates an integrated stabilisation layer beneath the resin bound surface. This helps maintain surface integrity and performance over time on raised roof terrace applications.



### CLEAN EDGE DETAIL

Both straight and curved edge profiles are available to form crisp boundaries and flowing shapes. Curved sections can be bent to shape on site, allowing precise detailing to suit the design.

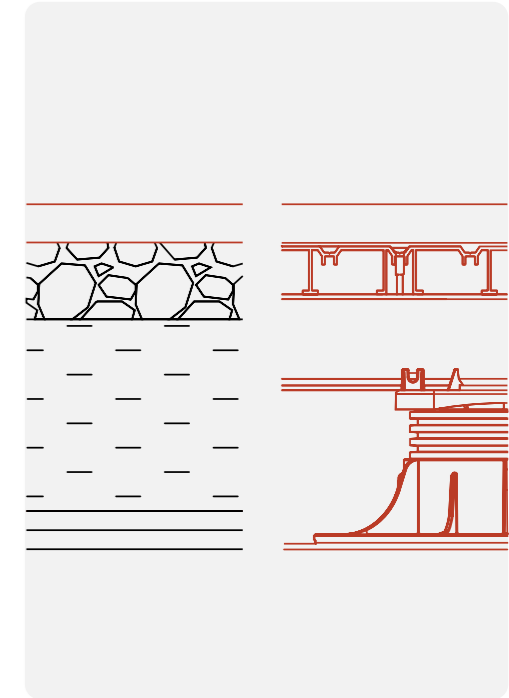

### LIGHTWEIGHT SOLUTION

A raised construction delivers a resin bound finish without the weight of a traditional bonded build-up. This makes it suitable for roof structures where load capacity is a key consideration.

\*EPDs available for components of this system.



# TERRASMART WET POUR RUBBER CRUMB

**LIGHTWEIGHT RAISED FLOORING SYSTEM WITH A DURABLE RUBBER CRUMB FINISH FOR ROOF TERRACES AND PODIUMS.**

The TerraSmart Wet Pour Rubber Crumb system is a lightweight, raised surface solution ideal for roof terraces and elevated play areas. Certified to B<sub>ROOF</sub>(t4) fire classification, it provides a safer, slip-resistant alternative to traditional paving or decking. With options to suit applications requiring fall-safe performance, the system combines versatility with durability, allowing for creative design flexibility with a wide range of colours.

- B<sub>ROOF</sub>(t4) certified
- Slip-resistance surface, suitable for play areas
- Range of 22 colour options for design flexibility
- Fully integrated raised system
- Very low maintenance
- Complies with BS EN 1177 & BS 7188 for playground safety
- Durable, low-maintenance surfacing

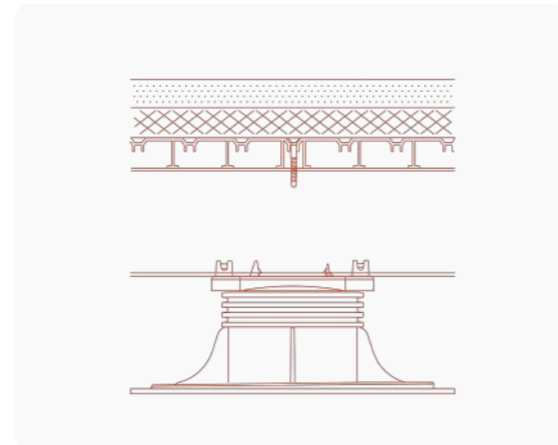

**B<sub>ROOF</sub>(t4)**

**WIND UPLIFT READY**

**FALL SAFE**

OPTIONS AVAILABLE

**COMPONENT EPDs AVAILABLE\***

\*EPDs available for components of this system.

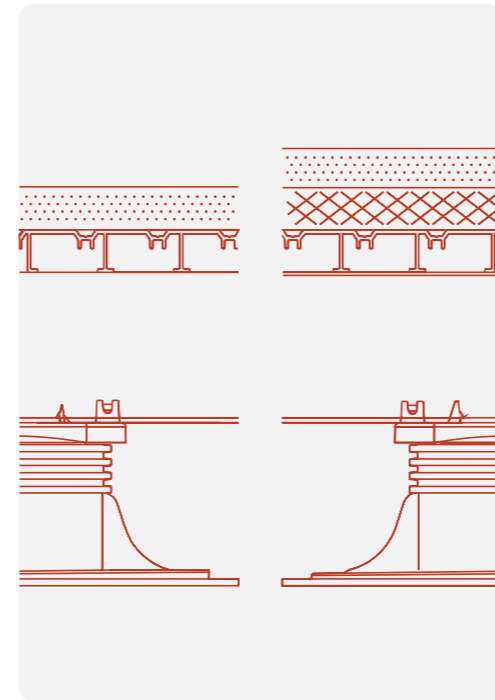

## FALL SAFETY BUILD-UPS

System build-ups are designed to accommodate different critical fall height requirements. Varying rubber depths allow the surface to be specified for safe play and activity environments on roofs.



## FORMED EDGE DETAIL

Edge profiles allow the wet pour surface to be neatly formed to straight runs and curves. This supports clean perimeter detailing and smooth transitions to adjacent systems.

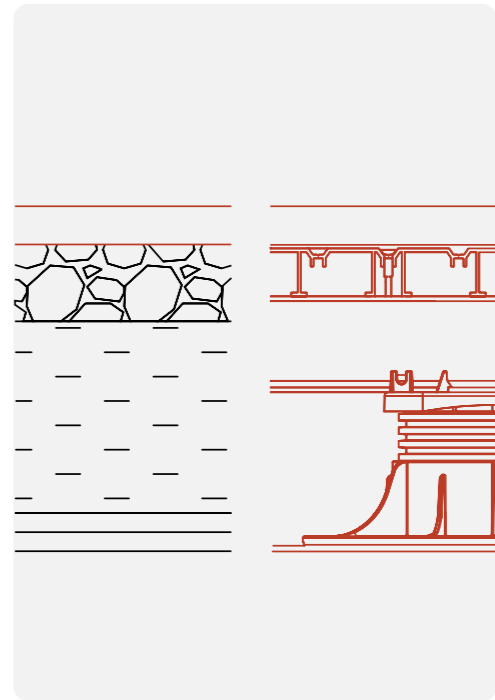

## LIGHTWEIGHT RAISED SYSTEM

A raised construction delivers impact-absorbing surfacing without the weight of a traditional bonded build-up. This makes the system suitable for roof terraces, podiums and play spaces with structural limits.

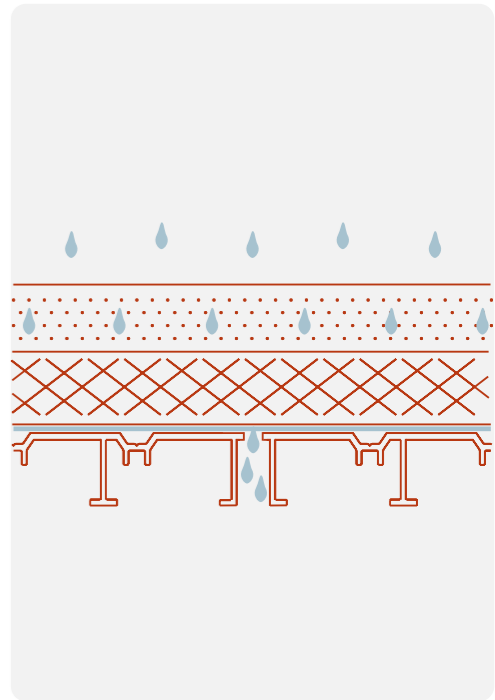

## WATER PERMEABLE SURFACE

The wet pour rubber crumb surface allows water to drain through the build-up. This helps manage surface water effectively and supports roof drainage performance.

# TERRASMART ARTIFICIAL GRASS

**RAISED, LIGHTWEIGHT FLOORING SYSTEM WITH A BIO-BASED ARTIFICIAL GRASS FINISH.**

The TerraSmart Wet Pour Rubber Crumb system is a lightweight, raised surface solution ideal for roof terraces and elevated play areas. Certified to B<sub>ROOF</sub>(t4) fire classification, it provides a safer, slip-resistant alternative to traditional paving or decking. With options to suit applications requiring fall-safe performance, the system combines versatility with durability, allowing for creative design flexibility with a wide range of colours.

- B<sub>ROOF</sub>(t4) certified
- Fully integrated raised flooring system
- Adjustable BaseBoard platform for precision levelling
- Compatible with all TerraSmart Systems
- Lightweight build for rooftop applications
- Quick, clean installation
- Durable and low-maintenance
- Sustainable finish with recycled and bio-based materials

\*EPDs available for components of this system.

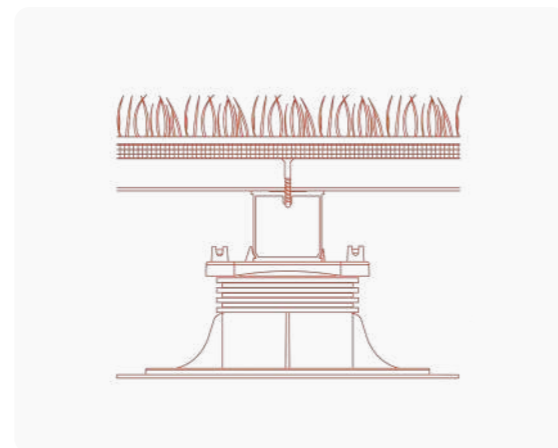

**B<sub>ROOF</sub>(t4)**

**POST-CONSUMER  
RECYCLED  
FIBRES**

**COMPONENT  
EPDs  
AVAILABLE\***

**SOYBEAN-BASED  
BIO-BACKING**

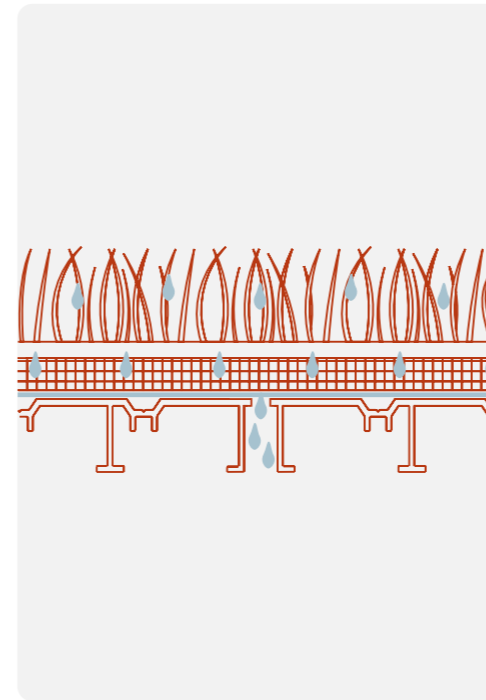

### PERMEABLE GRASS SURFACE

The artificial grass surface allows water to drain through the build-up. This promotes effective surface water management on raised terraces and balconies.



### BIO-BASED BACKING

Premium artificial grass is stitched into a bio-based backing using renewable materials like soybeans. This enhances sustainability while supporting a natural, cohesive surface finish.



### CLEAN EDGE DETAIL

Edge profiles allow the grass to be neatly formed to straight runs and curves. This supports crisp transitions to adjacent surfaces and integrates seamlessly on terraces.

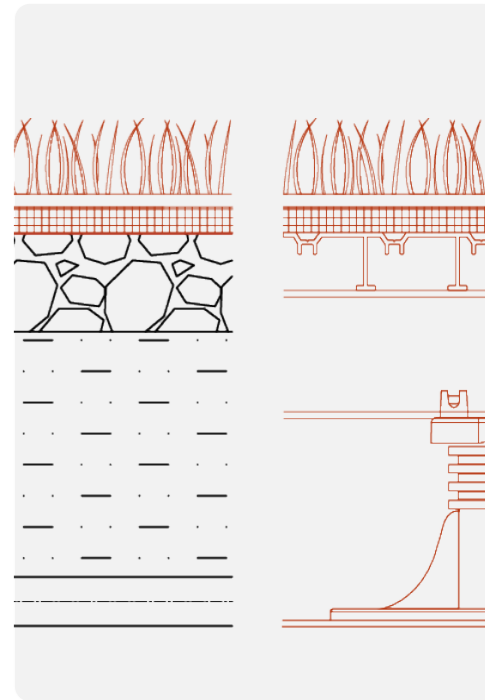

### LIGHTWEIGHT BUILD UP

A lightweight raised flooring construction supports the grass finish without a heavy bonded build-up. This makes it well suited to roof terrace applications with structural constraints.



# PLANTER SYSTEMS

Planters bring structure, depth and definition to roof terraces, helping to create distinct zones for planting and seating. Designed as raised, adjustable systems that do not interrupt the waterproofing, they provide a stable base while supporting flexible, integrated landscape design.



# TERRASMART CONTOUR BESPOKE PLANTER

**BESPOKE FABRICATED PLANTER SYSTEM FOR DESIGNS FEATURING WAVES AND CURVES.**

TerraSmart Contour, a completely bespoke planter system. Crafted for curves, waves, and radial designs. The panels come in virtually any size and integrate seamlessly with optional lighting, seating, and bespoke elements. Choose from a range of finishes and select the fixing method that is right for your project.

- Bespoke panels made in almost any size
- Popular heights range between 200 and 1100mm
- Continuous curved edge and circular planter options
- Bespoke integrated seating and detailing available
- Various integrated lighting options
- Wide range of finishes and materials
- Fix to concrete or the RYNO BaseBoard

\*EPDs available for components of this system.

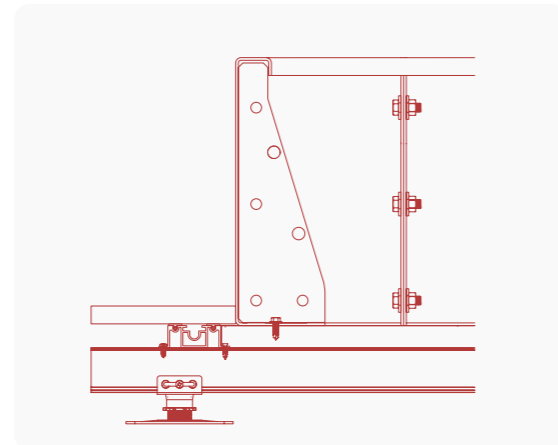

**60 YEAR SUBSTRUCTURE DESIGN LIFE**

**30 YEAR SUBSTRUCTURE WARRANTY**

COMPONENT EPDs AVAILABLE\*



## SEATING WITHIN THE LANDSCAPE

Planters can do more than frame planting. They can also help define places to pause, gather, and connect. Our planter systems can incorporate a range of seating options that integrate naturally with the terrace design. Depending on the layout and desired experience, seating can be integrated within the planter, recessed into the structure, cantilevered from the edge, or provided as freestanding elements alongside planting. Each approach creates different spatial and visual outcomes. We would be happy to discuss suitable seating integration options for your terrace design.



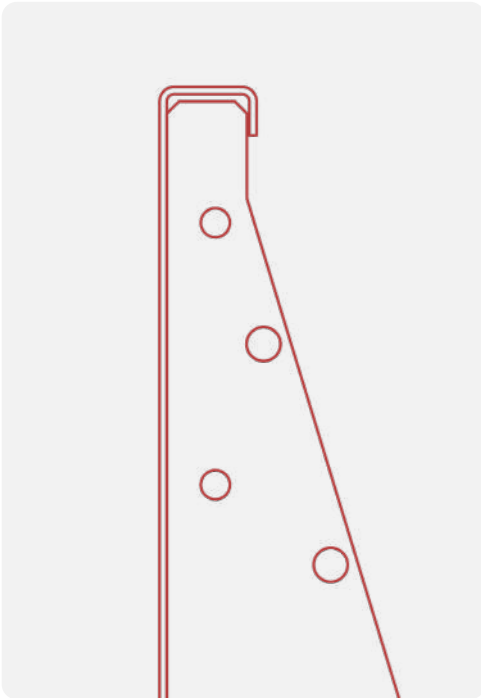

**TWICE-BENT TOP EDGE**

A twice-bent top edge creates a strong, defined planter profile. This adds visual weight, improves rigidity and delivers a robust, high-quality finish.



**LEVEL INSTALL AT SPEED**

Planters are supported by the TerraSmart baseboard system below. This allows fast, accurate levelling and installation across roof terrace structures.

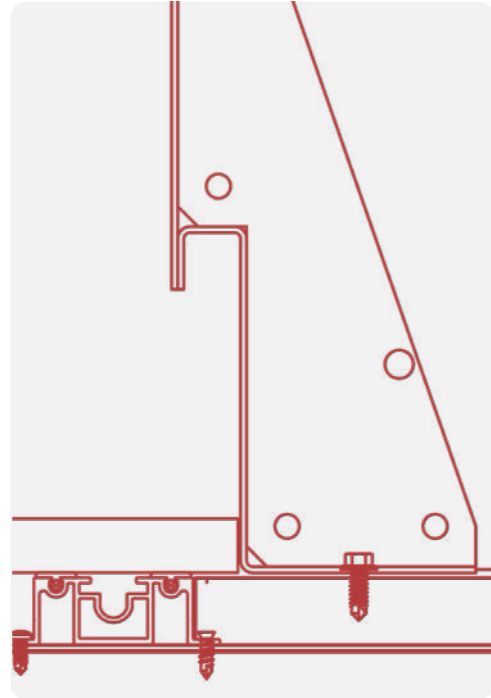

**INTEGRATED LIGHTING**

Optional integrated lighting can be incorporated within the planter design. This enables subtle illumination without additional surface-mounted fixtures.



**SMOOTH RADII**

Curved sections can be formed to smooth, continuous radii. This supports flowing layouts and soft transitions within roof terrace designs.

# TERRASMART LEDGE BESPOKE PLANTER

## BESPOKE FABRICATED PLANTER SYSTEM FOR DESIGNS FEATURING STRAIGHTS AND ANGLED CORNER DETAILS.

TerraSmart Ledge, a truly bespoke planter system designed for straight lines and angular corner details. The panels offer design flexibility, available in virtually any size and integrating seamlessly with optional lighting, seating, and custom elements. Select from a range of finishes and choose the fixing method that's right for your project.

- Bespoke panels made in almost any size
- Popular heights range between 200 and 1100mm
- Continuous edge and box planter options
- Bespoke integrated seating and detailing available
- Various integrated lighting options
- Wide range of finishes and materials
- Fix to concrete or the RYNO BaseBoard

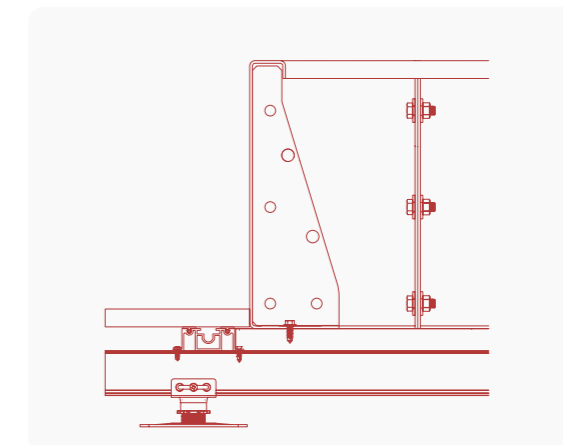

**60 YEAR  
SUBSTRUCTURE  
DESIGN LIFE**

**30 YEAR  
SUBSTRUCTURE  
WARRANTY**

COMPONENT  
**EPDs  
AVAILABLE\***

Icons \*EPDs available for components of this system.system



# TERRASMART EIGER PORCELAIN PLANTER

**GAME-CHANGING MODULAR PLANTER SYSTEM MADE WITH PORCELAIN TILES AND ALUMINIUM TRACKS.**

The TerraSmart Eiger Porcelain Planter is a patent pending modular planter system which uses aluminium tracks and porcelain tiles, opening up design freedom on roof terraces like never before. Available in both Classic and Contemporary styles, the Eiger system truly offers a solution suited to any design intent. Get creative with our vast collection of porcelain finishes and coatings or choose from 3 standard colour ways

- Modular kit of parts
- Unlimited design combinations
- Classic and Contemporary styles
- Integrated seating
- Budget friendly
- Short lead time

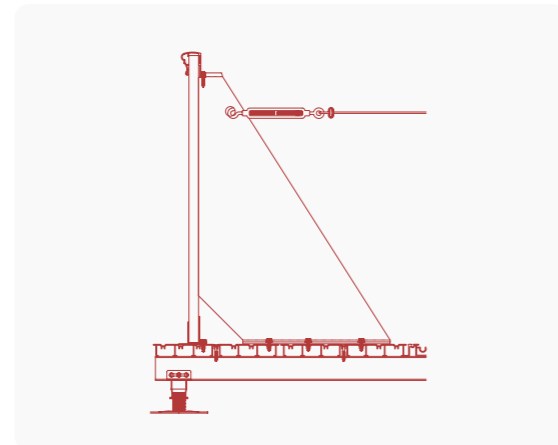

**60 YEAR  
SUBSTRUCTURE  
DESIGN LIFE**

**30 YEAR  
SUBSTRUCTURE  
WARRANTY**

COMPONENT  
**EPDs**  
AVAILABLE\*



\*EPDs available for components of this system.



## CLASSIC TOP EDGE

A profiled top edge delivers a refined, traditional planter detail. This is uniquely achieved through an aluminium profile, not possible with folded steel construction.



## CONTEMPORARY TOP EDGE

A clean, minimal top edge creates a sharp, modern planter aesthetic. This option suits contemporary schemes where crisp lines and simplicity are key.

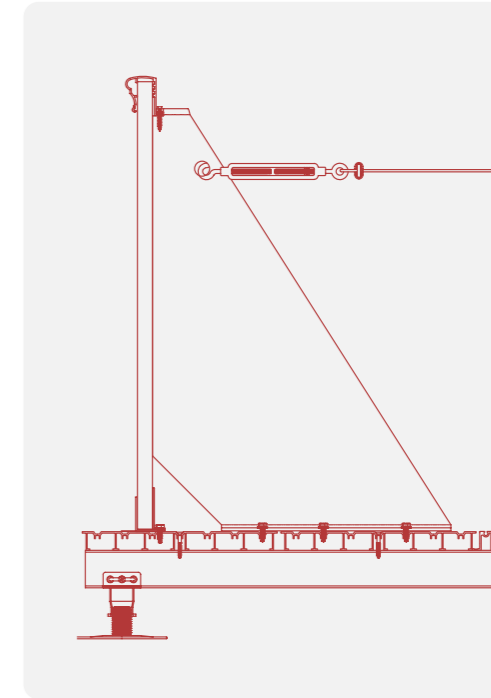

## SOLID SUPPORT FOOT

The Porcelain Planter Support Foot provides secure and robust support for the the system. Manufactured from zinc nickel electroplated mild steel, it delivers heavy-duty, corrosion-resistant support.



## RAPID DELIVERY TIMES

The system is constructed using stock porcelain tiles and aluminium profiles. This enables significantly faster delivery compared to traditionally fabricated steel planters.



# BALUSTRADE SYSTEMS

Balustrade systems simplify early design coordination. Integrated options that deliver zero waterproofing penetration alongside traditional fixed systems reduce complexity across trades while supporting safe, compliant roof terrace design.





# LINEAR TRACK BALUSTRADE

**VERSATILE BALUSTRADE SYSTEM ENABLING PRECISE ADJUSTMENT, COORDINATED DETAILING, AND OPTIONAL FIXING WITH ZERO WATERPROOFING PENETRATIONS.**

Linear Track is a versatile balustrade system engineered for diverse fixing conditions, with optional BaseLink integration enabling non-penetrative connection to TerraSmart subframes through the Rail-Fix variant. This creates a coordinated, terrace-mounted balustrade solution without disrupting waterproofing or sequencing.

- Complete integration with flooring systems
- Zero penetration of waterproofing
- 15° angled handrail prevents outward object slip
- Works across all standard fixing conditions
- Sliding base provides accurate angle adjustment
- Continuous infill-upright, clean-lined design
- 0.74kN and 1.5kN line load options

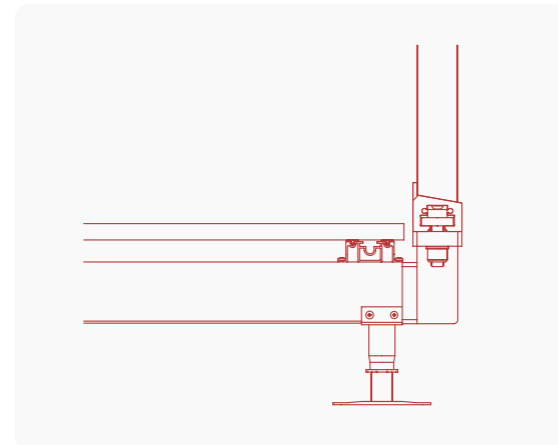

**REACTION TO FIRE**  
A2-s1, d0

**COMPONENT EPDs AVAILABLE\***

**ASSEMBLED SYSTEM WARRANTY 12 YEARS**

**UP TO 1.5kN LINE LOAD**

\*EPDs available for components of this system.



## ZERO PENETRATIONS

Linear track with BaseLink enables a structural balustrade connection directly into the terrace subframe. This creates a fixing detail that does not penetrate the waterproofing membrane - preserving envelope integrity and reducing long-term leak risk.

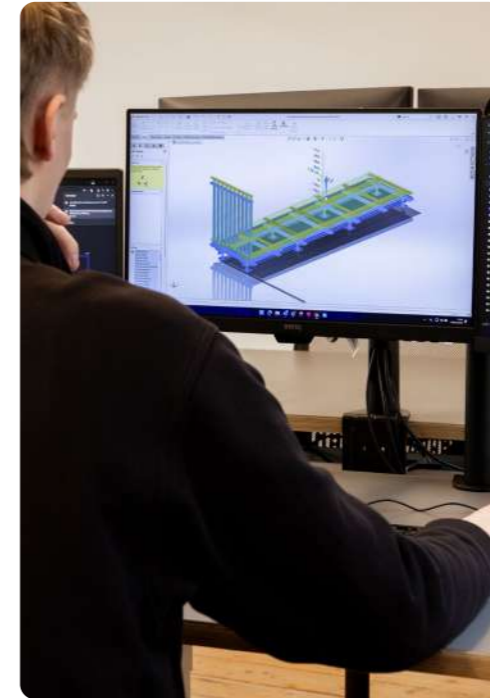

## LINE LOADS CONSIDERED

The system is engineered to meet horizontal line-load requirements of both 0.74kN and 1.5kN. This supports compliance across a wide range of roof terrace and occupied edge conditions.



## BASELINK COMPONENT

BaseLink provides a dedicated interface between the balustrade and the terrace subframe. This enables a coordinated fixing strategy that integrates structure, flooring and balustrade into a single system.

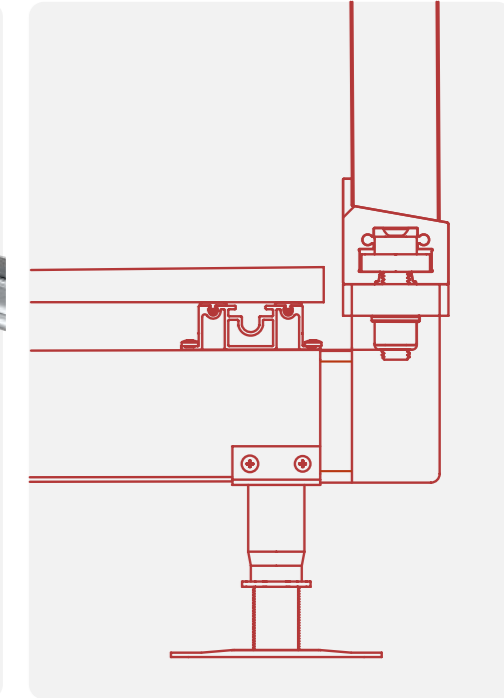

## COMPLETE INTEGRATION

Linear Track is designed to integrate seamlessly with TerraSmart flooring and subframe systems. This creates a clean, coordinated terrace edge without disrupting waterproofing or build sequence.



Balustrade penetrations are one of the most common pressure points in roof waterproofing. Every penetration adds complexity and risk, particularly when multiple trades are involved. This non-penetrating balustrade solution makes the whole build-up easier to coordinate and far more robust long term.

Oliver Sweeney | WeatherFix Waterproofing



## TRADITIONAL FIX BALUSTRADE SYSTEMS



### LINEAR PANEL

A modular balustrade system that utilises traditionally fabricated posts and our infill bar panels to create a clean look. Well suited to projects seeking simplicity, repetition and a strong architectural rhythm.



### LINEAR FLOW

A balustrade system incorporating a sloped base to support controlled drainage. Ideal for applications where drainage strategy and edge detailing need to work together.

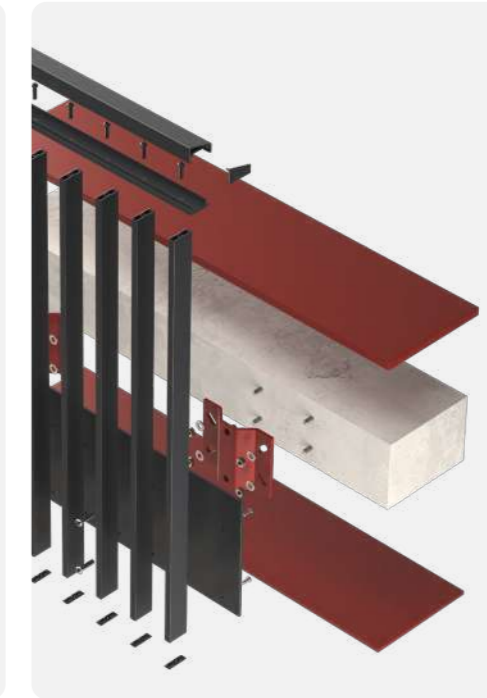

### LINEAR LIGHT

A lightweight balustrade solution designed for efficiency and ease of installation. A simple, clean design that's ideal for applications where drainage management is dealt with elsewhere.



### LINEAR FRAME

A face-fixed balustrade system with a strong structural expression. Offers a bold, architectural solution where the balustrade is intended to be a visible design feature.



# PEDESTAL PAVING SYSTEMS

Pedestal paving systems provide a simple, established approach to creating level roof terrace surfaces. Suited to residential and lower traffic environments, they offer a practical solution where a more traditional, less integrated build up is appropriate.

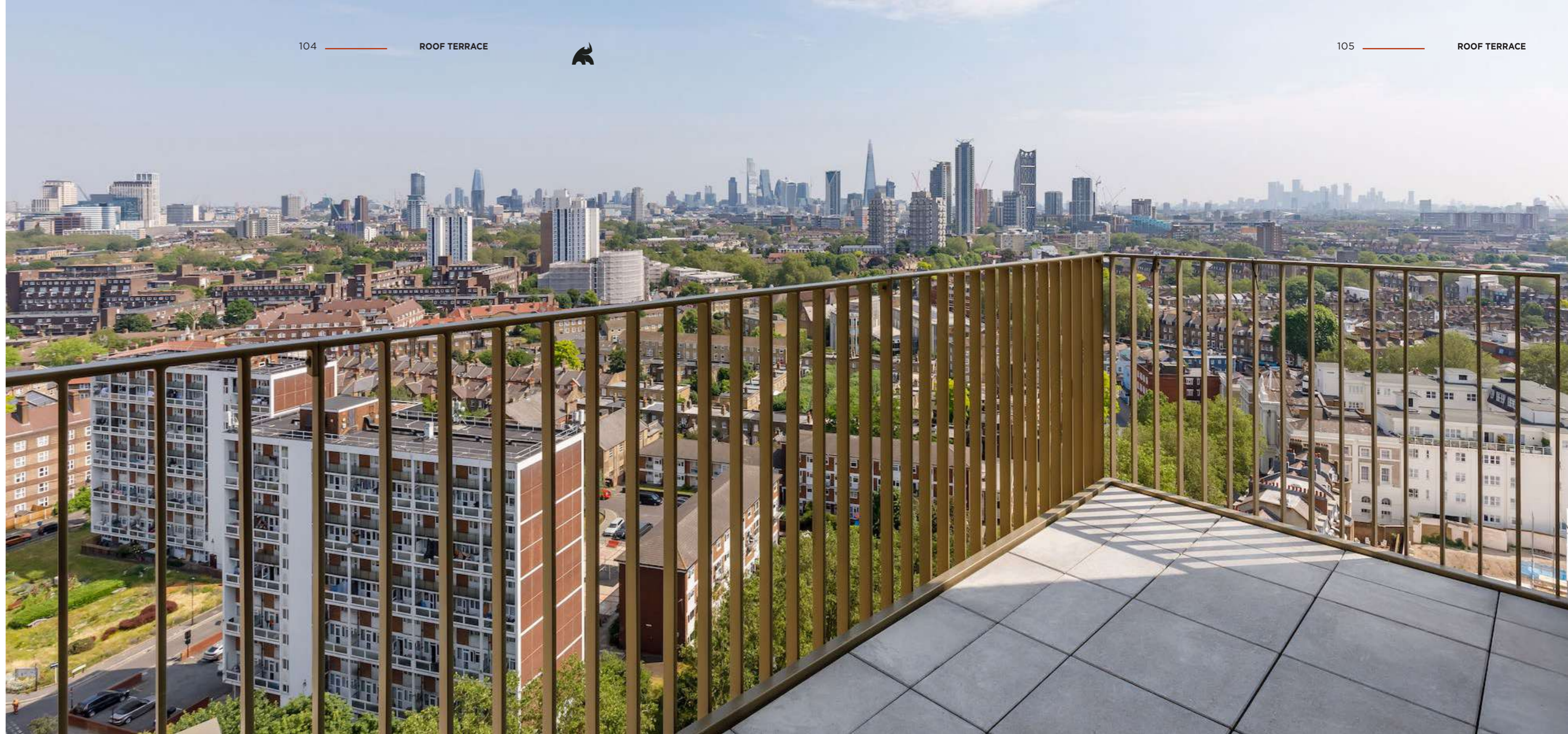



# RYNO NON-COMBUSTIBLE PEDESTAL PAVING

STRAIGHTFORWARD, ROBUST PAVING SYSTEM FOR WATERPROOFED SUBSTRATES.

Ryno Non-Combustible Pedestal Paving system offers a high quality yet economical solution for creating paved areas on terraces, inset balconies and other outdoor spaces.

- Non-combustible, A1 fire rated
- Full system build-up from as low as 30mm
- Unbeatably fast and simple installation process
- Wide range of paving finishes
- Designed to create grid, stack and brick-bond paving areas
- Wind uplift options available

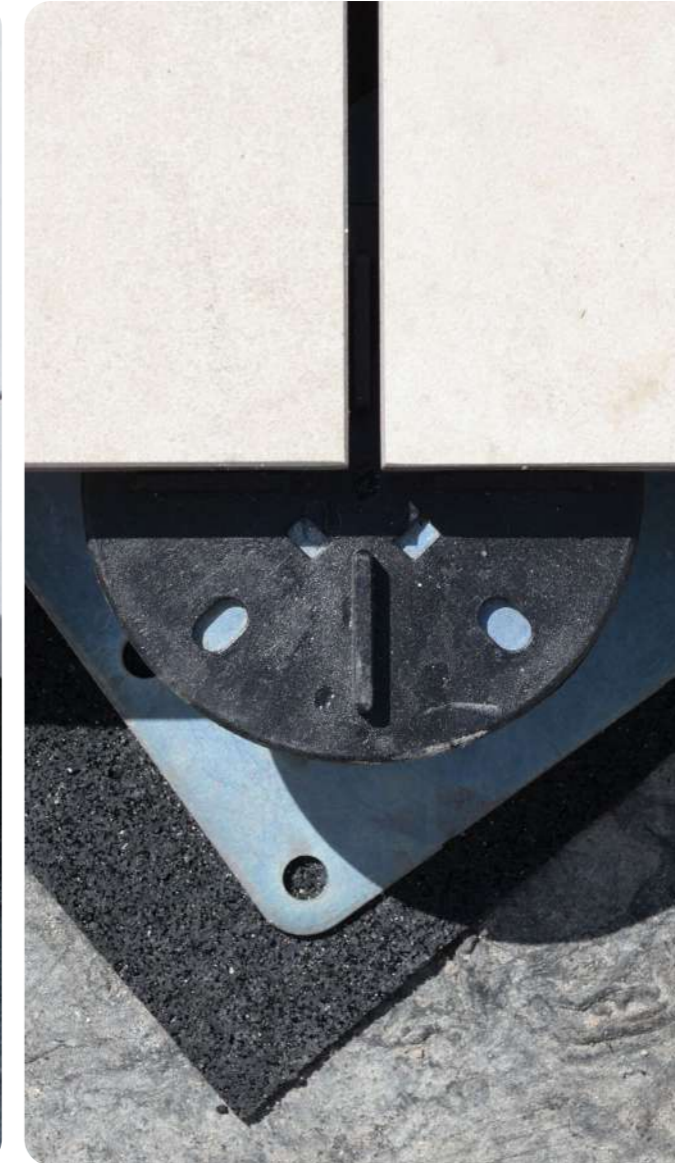
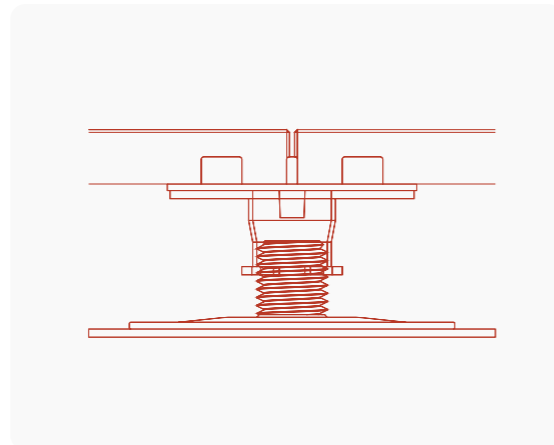

\*EPDs available for components of this system.

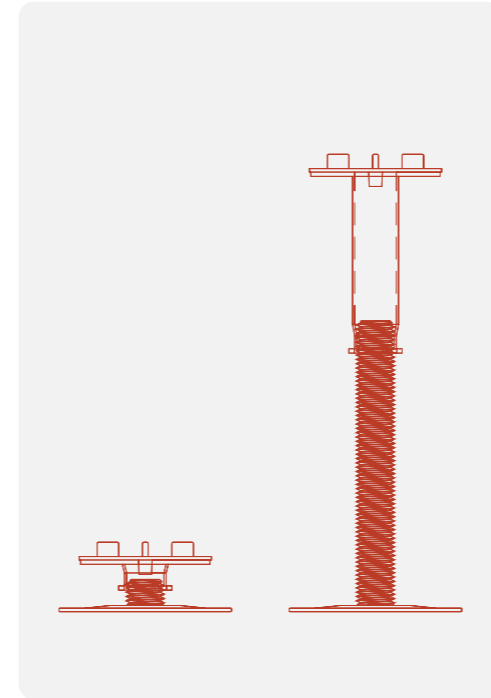
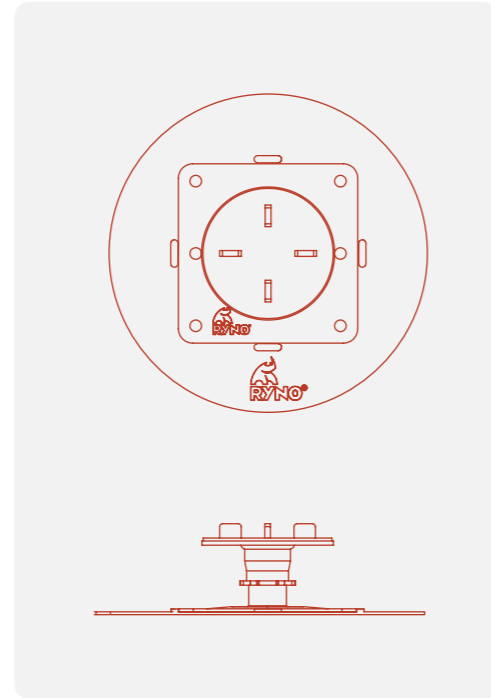
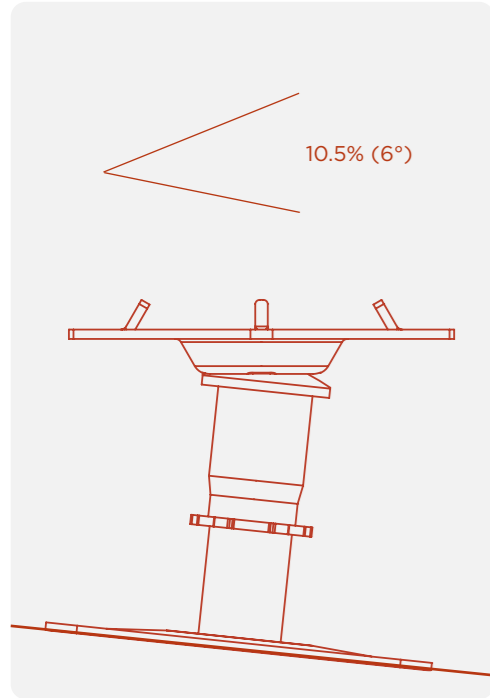

**SELF-LEVELLING ACTION**

The RPA-FR self-levelling option uses a locking, slope-correcting head to accommodate falls in the substrate. It provides slope correction up to 10.5% (6°), allowing pavers to sit flat without packing.

**ULTRA LOW HEIGHT**

For restricted build-ups, the RPS-FR stackable support is designed specifically for ultra-low height applications. Its stackable format allows tight height control using 2mm and 10mm stacking increments where standard pedestals won't fit.

**SPREAD THE LOAD**

Optional spreader plates fit beneath the pedestal base to increase bearing area and reduce point pressure on the substrate. Available in 170mm and 220mm sizes, they help distribute loads across the waterproofed substrate.

**LOCKED IN TIGHT**

The RP-FR pedestal uses threaded adjustment for accurate height setting, secured with a locking ring. This keeps the build-up stable once levels are set.

**HEIGHT NEEDS COVERED**

Across the range, pedestal heights run from 2mm (RPS-FR2) up to 1100mm (RP-FR-11). This covers low thresholds through to high build-ups within the same pedestal family.

**SPRING CLIP TENSION**

The edge spring clip is a spring-loaded stainless-steel component that tensions pavers away from abutments. It helps maintain a consistent perimeter drainage gap and reduces paver creep.

**SITE DELAYS RESOLVED**

The non-combustible pedestal extension adds an additional 25mm of adjustment when site heights change. This allows as-built differences to be accommodated without replacing pedestals.

**ZINC-NICKEL ELECTROPLATED**

Non-combustible pedestals are manufactured in steel with a zinc-nickel electroplated finish for corrosion resistance. This supports long-term durability in exposed rooftop conditions.



# RYNO CONVENTIONAL PEDESTAL PAVING

**STRAIGHTFORWARD, ROBUST PAVING SYSTEM FOR WATERPROOFED SUBSTRATES, WHERE NON-COMBUSTIBILITY ISN'T REQUIRED.**

The Ryno Conventional Pedestal Paving system offers a simple and economical solution for creating paved areas on terraces, podiums and other outdoor spaces.

- Large height range adjustability from 23-1000mm
- Full system build-up from as low as 30mm
- Unbeatably fast and simple installation process
- Wide range of paving finishes
- Designed to create grid, stack and brick-bond paving areas

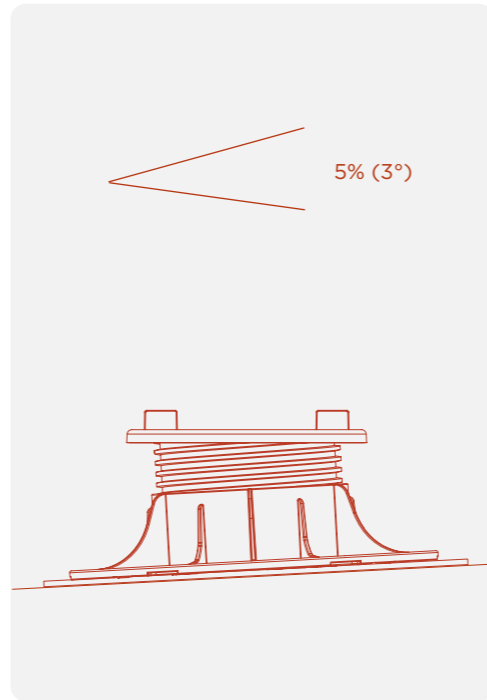
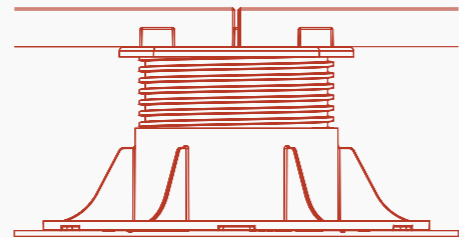

## SELF-LEVELLING

An optional self-levelling head accommodates falls in the substrate. This allows pavers to sit flat without packing, with maximum slope correction of 5% (1:20 gradient).



## ULTRA LOW HEIGHT

Low-profile pedestal options support installations where build-up height is restricted. Suitable for thresholds and refurbishments, with build-ups starting from as little as 1mm.



## BUILD IT UP

A wide range of pedestal heights allows the system to accommodate varying build-ups. Options range from RPS-1 at 1mm through to RPA-14 covering 930-1030mm, supporting complex terrace and balcony layouts.

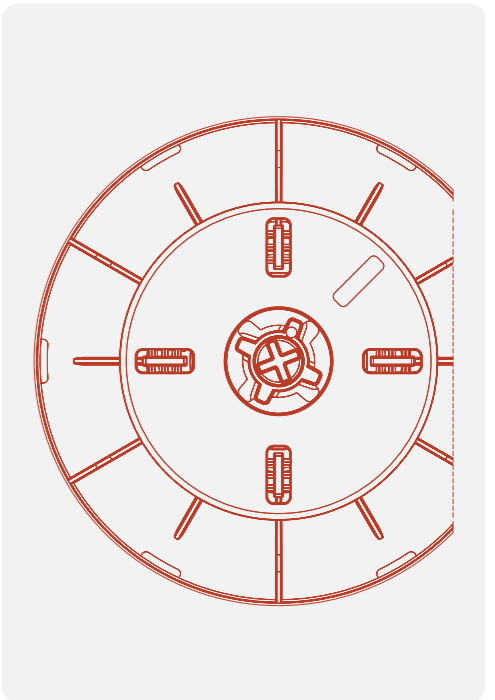

## CUT OFF BASE

The pedestal base can be trimmed where required to suit tight detailing conditions. This provides additional flexibility around edges, corners and perimeter constraints.

\*EPDs available for components of this system.



# SUSTAINABILITY

## DESIGNED FOR PERFORMANCE. ENGINEERED FOR THE PLANET.

Delivering sustainable roof terraces isn't just about materials, it's about creating systems that perform over time, reduce waste, and support long-term environmental goals.

At RYNO, sustainability is built into how we design, manufacture, and support every terrace system.

## A PERFORMANCE-LED APPROACH

- Long-life systems reduce replacement cycles and embodied carbon.
- Designed as complete integrated solutions, minimising waste and rework.
- Focus on durability, efficiency, and lifecycle performance.



## MATERIALS THAT WORK HARDER

We prioritise materials that balance performance with environmental responsibility:

- **Aluminium** - 100% recyclable and retains quality indefinitely.
- **Composite decking** - incorporates recycled plastics and hardwood waste.
- **Porcelain** - manufactured using closed-loop and water recycling systems.
- **Steel** - zero-waste manufacturing and ultra-durable finishes.



## MEASURED, NOT ASSUMED

**We believe sustainability should be transparent, comparable, and backed by real data:**

### LIFE CYCLE ASSESSMENT (LCA)

Conducted across our systems to evaluate impact from raw material to end-of-life, informing product development and material selection

### GLOBAL WARMING POTENTIAL (GWP)

Reported within EPDs, providing a clear carbon footprint per product (e.g. kgCO<sub>2</sub>/m<sup>2</sup> over service life)

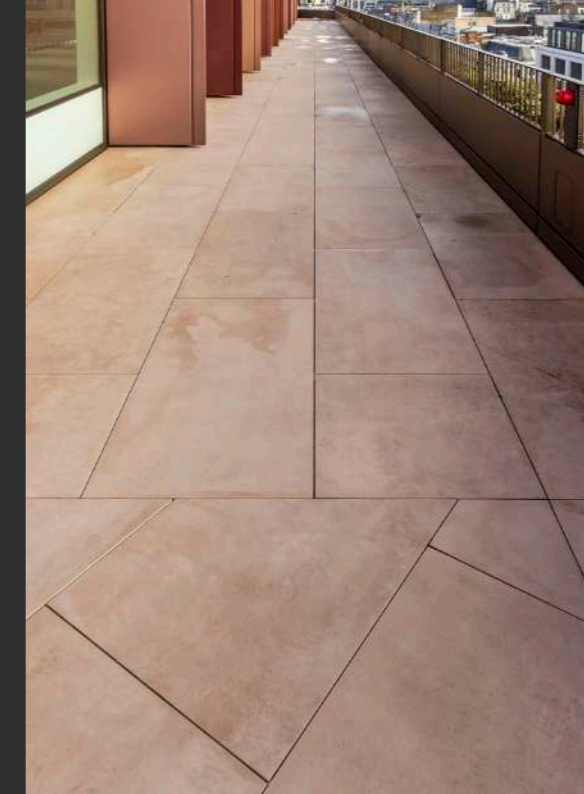

### ENVIRONMENTAL PRODUCT DECLARATIONS (EPDS) Available for:

- -95% of porcelain tiles (excluding Quadro range)
- Adjustable non-combustible pedestals (excluding low-height stackable supports)
- EPD's in development: Mill-finish aluminium, PPC aluminium, Vitrified Composite and Planters.

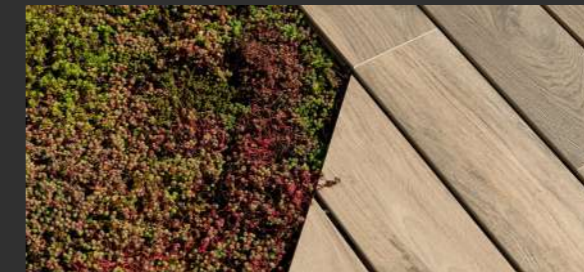

## VERIFIED STANDARDS

**Our sustainability approach is underpinned by recognised, audited certifications:**

- **ISO 14001: ENVIRONMENTAL MANAGEMENT** Covers all operations and manufacturing processes, ensuring reduced waste, emissions, and resource use.
- **ISO 45001: HEALTH, SAFETY AND WELLBEING** Supporting responsible, people-focused delivery across projects.
- **ISO 9001: QUALITY AND OPERATIONAL PERFORMANCE** Ensuring consistent, efficient systems that reduce rework and material waste.

From verified data to long-life materials, every decision is made to support better specification. Giving you the confidence to design roof terraces that meet performance demands today and environmental expectations tomorrow.



**TALK TO SOMEONE  
WHO DOES THIS  
EVERY DAY...**

EMAIL  
[hello@rynosystems.com](mailto:hello@rynosystems.com)

PHONE  
+44 203 967 3500

# ENHANCING LIFE ON THE SKYLINE.



**ARE YOU READY TO  
FINISH STRONG?**

**RYNO LTD**

hello@rynosystems.com  
+44 (0) 203 967 3500  
rynosystems.com

**HEAD OFFICE**

Castlepoint,  
Castle Way, Ellon  
AB41 9RG

**LONDON STUDIO**

2 Sutton Lane  
London  
EC1M 5PU

**ASHFORD OFFICE**

24 Cobalt Building,  
1600 Eureka Park, Kent  
TN25 4BF